



**MOTOROLA**  
*intelligence everywhere™*



**XTS™ 3000 ASTRO®**  
Digital Portable Radio  
Model III  
User Guide





# ASTRO

## Digital XTS 3000 Model III Portable Radio

### Quick-Reference Card

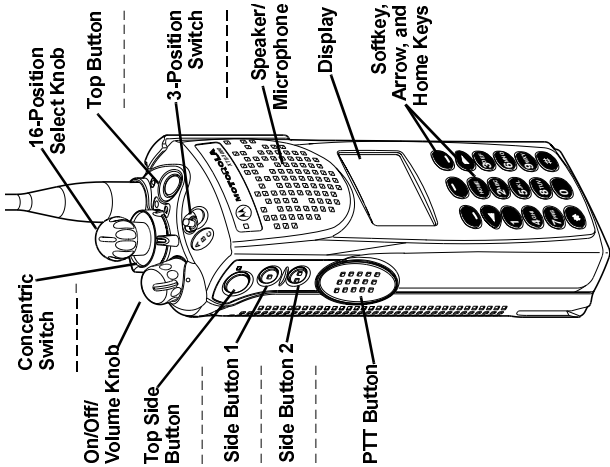

Write your radio's programmed features on the dotted line.

### GENERAL

Turning the Radio On: Rotate the On/Off/Volume Control knob clockwise.

#### Monitoring (Conventional Channels Only):

Momentarily press the **Monitor** button and listen for voice activity.

**Transmitting:** Press and hold the **PTT** button.

**Receiving:** Release the **PTT** button.

#### Selecting a Zone and Channel:

- 1 Press **▷** until the **ZONE** softkey appears.
- 2 Press **◁** directly below **ZONE**.
- 3 Press **▷** until the desired zone name appears.
- 4 To select the zone, press **◀** or the **PTT** button.

FOLD

FOLD

### COMMON RADIO FEATURE

#### Making an Individual Call

- 1 Press **▷** until one of the following softkeys appears:

**PHONE** for Telephone Call

**CALL** for a Private-Conversation Call

**PAGE** for a Call-Alert Page

**OR**

Press the **PHONE**, **CALL**, or **PAGE** button; then go to step 3.

- 2 Press **◁** directly below the desired softkey.
- 3 If you wish to call the last number dialed, press the **PTT** button.

**OR**

Press **◁** or **▷** until you locate the desired member ID. Then, press the **PTT** button.

## COMMON and SPECIAL RADIO FEATURES

Most of your radio features can be accessed by performing the following steps (for more detail, refer to the feature description in your manual).

- 1 Press **⏻** until the desired softkey appears (see "Softkey Feature List" at right).

OR

Press (or rotate) the preprogrammed feature button/switch (see front of card).

- 2 Press **⏻** directly below the desired softkey.

The display shows the current state of the feature and the available softkey choices.

- 3 If you want to change the feature state, press **⏻** directly below the desired softkey choice.

OR

If you do not want to change the feature state, press **⏻** or the **PTT button** to exit the feature.

### Softkey Feature List

CALL	Individual Private-Conversation Call or Selection Call
CHNN	Channel Selection
DIR	Bypass Repeater (Talkaround) and Talk Directly to Another Radio
ERRS	Erasure of Encryption Key(s)
LOGF	Radio Lock (Log Off)
INEX	Encryption Key(s) Index Grouping
MSG	Message-List Selection
MUTE	Keypad Tones Muting
PRBE	Call-Alert Page
PHON	Telephone Call
PROG	List Programming of Individual-Call Numbers and Scan Channels

PLUR	TX Power-Level Selection
RPGH	New Dynamic-Rerouting Request
SCNH	Scan Operation
SITE	Multiple Site Selection
STS	Status-List Selection
TGRP	Talkgroup Selection
VIEW	List Viewing
ZONE	Zone Selection



**MOTOROLA**

*intelligence everywhere™*

***XTS™ 3000 ASTRO®  
Digital Portable Radio  
Model III User Guide***

Motorola, Inc.  
8000 West Sunrise Blvd.  
Ft. Lauderdale, FL 33322

**6881083C75-A**

## Product Safety and RF Exposure Compliance



Caution

Before using this product, read the operating instructions for safe usage contained in the Product Safety and RF Exposure booklet enclosed with your radio.

### ATTENTION!

This radio is restricted to occupational use only to satisfy FCC RF energy exposure requirements. Before using this product, read the RF energy awareness information and operating instructions in the Product Safety and RF Exposure booklet enclosed with your radio (Motorola Publication part number 6881095C98) to ensure compliance with RF energy exposure limits.

### Computer Software Copyrights

The Motorola products described in this manual may include copyrighted Motorola computer programs stored in semiconductor memories or other media. Laws in the United States and other countries preserve for Motorola certain exclusive rights for copyrighted computer programs, including, but not limited to, the exclusive right to copy or reproduce in any form the copyrighted computer program. Accordingly, any copyrighted Motorola computer programs contained in the Motorola products described in this manual may not be copied, reproduced, modified, reverse-engineered, or distributed in any manner without the express written permission of Motorola. Furthermore, the purchase of Motorola products shall not be deemed to grant either directly or by implication, estoppel, or otherwise, any license under the copyrights, patents or patent applications of Motorola, except for the normal non-exclusive license to use that arises by operation of law in the sale of a product.

### Documentation Copyrights

No duplication or distribution of this document or any portion thereof shall take place without the express written permission of Motorola. No part of this manual may be reproduced, distributed, or transmitted in any form or by any means, electronic or mechanical, for any purpose without the express written permission of Motorola.

### Disclaimer

The information in this document is carefully examined, and is believed to be entirely reliable. However, no responsibility is assumed for inaccuracies. Furthermore, Motorola reserves the right to make changes to any products herein to improve readability, function, or design. Motorola does not assume any liability arising out of the applications or use of any product or circuit described herein; nor does it cover any license under its patent rights, nor the rights of others.

MOTOROLA, the Stylized M Logo and ASTRO are registered in the U.S. Patent & Trademark Office. All other product or service names are the property of their respective owners.

P25 radios contain technology patented by Digital Voice Systems, Inc.

© Motorola, Inc. 2003. All Rights Reserved. Printed in the U.S.A. 6/04.

# Contents

---

<b>Introduction . . . . .</b>	<b>1</b>
Notations Used in This Manual . . . . .	1
APCO Project 25 Radios . . . . .	2
Your XTS 3000 Model III Radio . . . . .	3
Physical Features of the XTS 3000 Model III Radio . . . . .	4
Programmable Controls . . . . .	4
Backlight . . . . .	5
LED Indicators . . . . .	5
Status Indicators . . . . .	6
Alert Tones . . . . .	7
Standard Accessories . . . . .	10
Antenna . . . . .	12
Belt Clip . . . . .	16
XTS 3000 R Radios Only . . . . .	19
<b>General Radio Operation . . . . .</b>	<b>21</b>
Turning the Radio On and Off . . . . .	21
Zones and Channels . . . . .	22
Transmitting and Receiving . . . . .	24
Using Lists . . . . .	26
General Radio Features . . . . .	30
<b>Common Radio Features . . . . .</b>	<b>37</b>
Conventional Squelch Options . . . . .	37
Data Calls (Status Calls or Message Calls) . . . . .	38
Emergency State . . . . .	39
Talkgroup Calls (Project 25 Radios Only) . . . . .	43
Individual Calls . . . . .	45
PL Defeat . . . . .	51
Repeater Access . . . . .	51
Repeater/Direct . . . . .	52
Scan . . . . .	53
Selecting Squelch Operation . . . . .	58
Smart PTT . . . . .	58
<b>Special Radio Features . . . . .</b>	<b>61</b>
Dynamic Regrouping . . . . .	61
PTT-ID Receive . . . . .	63

---

PTT-ID Transmit .....	63
Secure Operation .....	64
Selectable Power Level .....	69
Trunking System Controls .....	70

**Additional Information . . . . . 75**

Troubleshooting .....	75
Radio Care .....	76
Service .....	77
Battery .....	77

**Index . . . . . 79**



# Introduction

---

This manual describes how to operate an ASTRO® Digital XTS™ 3000 Type III Model III Portable Radio.



This manual discusses the following:

- General Radio Operation
- Common Radio Features
- Special Radio Features
- Helpful Tips

Use this manual to become familiar with your ASTRO radio.

## Notations Used in This Manual

Throughout the text in this publication, you will notice the use of **WARNINGS**, **Cautions**, and **Notes**. These notations are used to emphasize that safety hazards exist, and the care that must be taken or observed.

 WARNING	<b>An operational procedure, practice, or condition, etc., which may result in injury or death if not carefully observed.</b>
 Caution	An operational procedure, practice, or condition, etc., which may result in damage to the equipment if not carefully observed.

**Note:** An operational procedure, practice, or condition, etc., which is essential to emphasize.

The following special notations identify certain items:

<i>Example</i>	<i>Description</i>
<b>Light button</b>	Button names are shown in bold print.
⊖	Radio keys and buttons are shown as they appear on the radio.
PHON	Text appearing on the display is shown in a custom font.

## **APCO Project 25 Radios**

ASTRO Digital XTS 3000 radios are part of Motorola's Project 25 digital solution. When a radio is equipped with the ASTRO Digital CAI option, it complies with APCO Project 25 standards on conventional two-way radio systems and Common Air Interface (CAI) on digital trunked systems. Not only does the ASTRO Digital CAI option include Project 25 interoperable voice features, but other Project 25 compliant advanced digital signalling capabilities as well.

APCO Project 25 is the creation of the Association of Public Safety Communication Officers (APCO). It brings together representatives of various user groups to evaluate basic technologies in advanced land mobile radios to find common solutions to best serve the marketplace.

## Your XTS 3000 Model III Radio

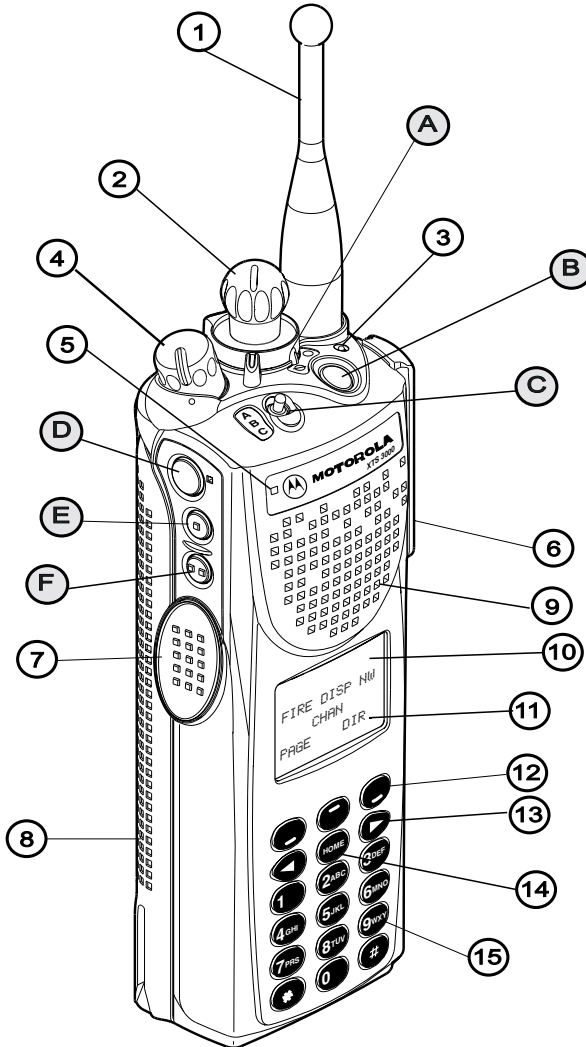

**Note:** Physical features are denoted by number (see Table 1 on page 4). Programmable controls are denoted by alphabet lettering (see Table 2 on page 4).

## Physical Features of the XTS 3000 Model III Radio

**Table 1: Physical Features**

<b>No.</b>	<b>Feature</b>	<b>Page</b>	<b>No.</b>	<b>Feature</b>	<b>Page</b>
1	Antenna	12	9	Speaker	
2	16-Position Select Knob	23	10	Liquid Crystal Display (LCD)	
3	LED	5	11	Soft Keys (bottom 2 lines of LCD)	
4	On/Off/Volume Control Knob	21	12	Soft key selection buttons	
5	Microphone		13	Arrow Keys	
6	Universal Connector Cover	17	14	Home Key	
7	PTT (Push-to-Talk) Button	24	15	Alphanumeric Keypad	
8	Battery	10			

## Programmable Controls

The following radio controls can be programmed to activate certain software features.

**Table 2: Programmable Controls**

<b>No.</b>	<b>Feature</b>	<b>No.</b>	<b>Feature</b>
<b>A</b>	2-Position Concentric Switch	<b>D</b>	Top Side (Select) Button
<b>B</b>	Orange Top Button	<b>E</b>	Side Button 1
<b>C</b>	3-Position A/B/C Switch	<b>F</b>	Side Button 2

The features that can be assigned to these controls by a qualified radio technician, and the pages where these features can be found are listed in Table 3 on page 5.

**Note:** Any references in this manual to controls that are preprogrammed mean that a qualified radio technician must use the radio's programming software to assign a feature to a control. Contact your system administrator for details.

**Table 3: Programmable Features**

<i>Feature</i>	<i>Page</i>	<i>Feature</i>	<i>Page</i>	<i>Feature</i>	<i>Page</i>
Call Response	50	Nuisance Delete	55	Secure/Clear	64
Channel	23	PL Defeat	51	Site Lock/ Unlock	71
Dynamic Priority	55	Repeater/Direct	52	Site Search	72
Emergency	39	Reprogram Request	62	Volume Set	25
Light/Backlight	5	Scan On/Off	53	Zone	22
Monitor	25	Scan List Programming	56		

## Backlight

If poor light conditions make the channel numbers (around the **16-Position Select knob**) difficult to read, turn on the radio's backlight by pressing the preprogrammed **Light button** if applicable.

These lights remain on for a preprogrammed time before they turn off automatically, or you can turn them off immediately by pressing the **Light button** again.

## LED Indicators







The LED on top of the radio indicates the radio's operating status:

**Table 4: LED Indicators**

<i>LED Indicator</i>	<i>What it Means</i>
Red	Radio transmitting
Flashing red	Channel busy, or Low battery (while transmitting)
Double flashing red	Receiving encrypted audio
Flashing green	Receiving an individual call

## Status Indicators

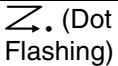
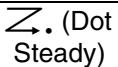
Below are icons that may appear at various times on your radio's display:

<b>Symbol</b>	<b>Indicator Name</b>	<b>Description</b>
	Battery Status	Flashes when the battery is low.
	Carrier Squelch	Indicates the radio is operating in the carrier-squelch mode.
	Secure Operation	Appears when your radio is operating in secure mode. Does not appear when your radio is operating in clear mode. Flashes when an encrypted voice call is being received.
	Call Received	Flashes an individual call is received.
	Scan	Indicates the radio is scanning.
	Priority 1 Channel Scan	Indicates the radio is scanning the priority-one channel.
	Priority 2 Channel Scan	Indicates the radio is scanning the priority-two channel.
	View/Programming	Indicates the radio is in list view or programming mode; lights steady in view mode and flashes in programming mode.
	Direct	Indicates whether you are talking directly to another radio (talkaround) or through a repeater; on = direct; off = repeater. Appears when you are talking directly to another radio instead of through a repeater (that is, your radio is in talkaround mode).

## Alert Tones

An alert tone is a sound or group of sounds. Your radio uses alert tones to inform you of your radio's conditions. The following table lists these tones and when they occur.

<b>Sound</b>	<b>Tone Name</b>	<b>Occurs:</b>
<b>Short, Low-Pitched Tone</b>	Invalid Key-Press	When the wrong key is pressed.
	Radio Self-Test Fail	When the radio fails its power-up self test.
	No ACK Received	When the radio fails to receive an acknowledgement from the dispatcher.
	Reject	When an unauthorized request is made.
	Time-Out Timer Warning	Four seconds before time out.
<b>Continuous, Low-Pitched Tone</b>	Time-Out Timer Timed Out	After time out.
	Talk Prohibit/ PTT Inhibit	When the <b>PTT button</b> is pressed and transmissions are not allowed.
	Out-of-Range	When the <b>PTT button</b> is pressed and the radio is out of range of the system.
	Invalid Mode	When the radio is on a channel that is not programmed.
	Individual Call Warning Tone	When the radio is in an individual call for greater than six seconds without any activity.
<b>A Group of Low-Pitched Tones (Busy Tone)</b>	Busy	When a channel, phone line, or system is unavailable due to high traffic volume.

<b>Sound</b>	<b>Tone Name</b>	<b>Occurs:</b>
<b>Short, Medium-Pitched Tone</b>	Valid Key-Press	When the correct key is pressed.
	Radio Self-Test Pass	When radio passes its power-up self test.
	Clear Voice	At the beginning of a non-coded communication.
	Priority Channel Received	Upon receipt of activity on a priority channel.
	Emergency Alarm Entry	Upon entering emergency state.
	Central Echo	When the central controller has received a request from a radio.
<b>Continuous, Medium-Pitched Tone</b>	Volume Set	Sounds when volume level is adjusted on a quiet channel.
	Emergency Exit	Upon exiting emergency state
	PTT Sidetone	When data is sent by pressing the <b>PTT button</b> , but the user must wait to talk.
<b>A Group of Medium-Pitched Tones</b>	Failsoft	When system fails.
	Automatic Call Back	When voice channel becomes available in response to a previous request.
	Talk Permit	Upon pressing the <b>PTT button</b> ; verifying system accepting transmissions.
	Dispatcher-Interrupter	Upon receipt of a dispatcher-interrupt call.
	Keyfail	When an encryption key has been lost.
	Console Acknowledge	When a status, message, emergency alarm, or reprogram request ACK is received.
	Received Individual Call	When a Call Alert or Private Conversation call is received.
	Call Alert Sent	When a Call Alert is received by the target radio.
<b>Short, High-Pitched Tone (Chirp)</b>	Low-Battery Chirp	When battery level is below preset threshold value
	Phone Dekey Chirp	When switching from radio to phone line upon releasing the <b>PTT button</b> .



<b><i>Sound</i></b>	<b><i>Tone Name</i></b>	<b><i>Occurs:</i></b>
<b><i>Continuous, High-Pitched Tone</i></b>	Quik-Call™ Group Call	When a Quik-Call group call is received
<b><i>A Group of High-Pitched Tones</i></b>	Quik-Call Individual Call	When a Quik-Call individual call is received
<b><i>Ringling</i></b>	Phone Ringing	When a phone call is received
	Enhanced Call Received	When originator receives ACK from an enhanced private call
<b><i>Gurgle</i></b>	Dynamic Regrouping/ Over-The-Air Programming	When a dynamic ID has been received and the <b>PTT button</b> is pressed and the reprogrammed group has not been selected and when the radio is successfully re-keyed

## Standard Accessories

### Battery



WARNING

To avoid a possible explosion:

- **DO NOT** replace the battery in any area labeled “hazardous atmosphere.”
- **DO NOT** discard batteries in a fire.



Caution

If your radio is programmed with volatile-key retention (consult your service technician), encryption keys are retained for approximately 30 seconds after battery removal.

### Battery Life

Battery life is determined by several factors. Among the more critical are the regular overcharge of batteries and the average depth of discharge with each cycle. Typically, the greater the overcharge and the deeper the average discharge, the fewer cycles a battery will last. For example, a battery which is overcharged and discharged 100% several times a day, lasts fewer cycles than a battery that receives less of an overcharge and is discharged to 50% per day. Further, a battery which receives minimal overcharging and averages only 25% discharge, lasts even longer.



WARNING

**Care should be taken to avoid external short circuiting of the battery. A sustained high-rate discharge (for example, a paper clip placed accidentally across the battery contacts) may permanently damage the battery, void the battery warranty, and create a burn or fire hazard.**

## Charging the Battery

Motorola batteries are designed specifically to be used with a Motorola charger and vice versa. Charging in non-Motorola equipment may lead to battery damage and void the battery warranty.

The battery should be at about 77°F (25°C) (room temperature), whenever possible. Charging a cold battery (below 50° F [10°C]) may result in leakage of electrolyte and ultimately in failure of the battery. Charging a hot battery (above 95°F [35°C]) results in reduced discharge capacity, affecting the performance of the radio. Motorola rapid-rate battery chargers contain a temperature-sensing circuit to ensure that batteries are charged within the temperature limits stated above.



**WARNING**

**Do not attempt to change or charge the battery in a hazardous atmosphere.**

To charge the battery, place the battery (with or without the radio) in a Motorola-approved charger. The charger's LED indicates the charging progress; see your charger user guide for details.

## Attaching the Battery

To attach the battery:

- 1 Turn off the radio and hold it with the back of the radio facing upward.
- 2 Align the three slots at the top of the battery with the three tabs on the back of the radio.
- 3 Push the battery down toward the radio until the battery clicks into place.

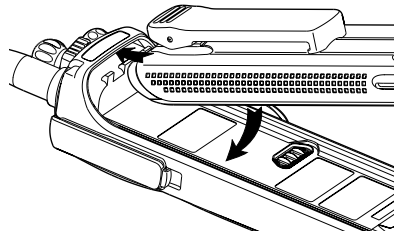

## Remove the Battery

To remove the battery:

- 1 Turn the radio off.
- 2 Hold the radio with the back of the radio facing upward.
- 3 To release the battery from the radio, push the battery release button located on the bottom of the battery.
- 4 Lift the battery away from the radio and remove.

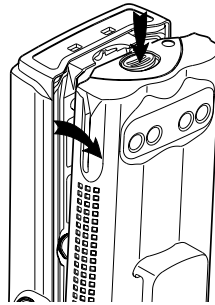

**Note:** If your radio is programmed with volatile-key retention, encryption keys are retained for approximately 30 seconds after battery removal. Consult a qualified radio technician for details.

## Antenna

### Radio Operating Frequencies

Before installing the antenna, ensure that the antenna you have can be used with your radio. Your radio's model number is on a label attached to the back of your radio. A typical model number might be H09UCC9PW5AN. The fourth position of the model number (in this example, U) identifies the operating-frequency band of the radio. The following table lists all fourth-position alpha characters and corresponding frequency band.

Fourth Position	Operating Frequency	Fourth Position	Operating Frequency
K	136-178MHz	R	403-470MHz
S	450-512MHz	U	806-870MHz

Antennas are frequency sensitive and are color coded according to the frequency range of the antenna. The color code indicator is in the center of the base of the antenna. The following illustrations and table helps identify the antenna, antenna frequency range, and corresponding color code.

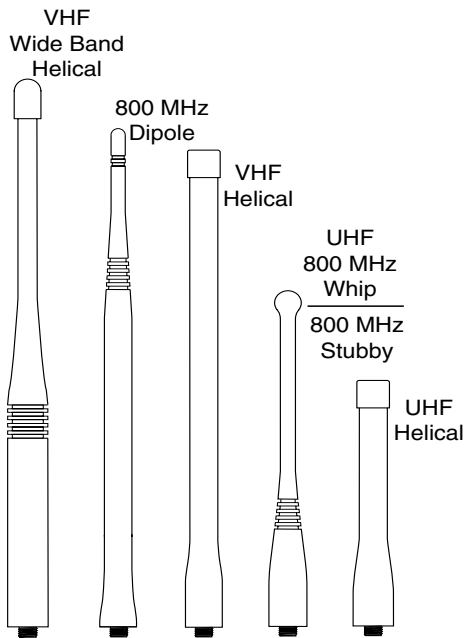

<b>Antenna Identification Table</b>					
Antenna Type	Approx. Length		Insulator Color Code	Frequency Range	Antenna Kit No.
	in.	mm			
VHF Wide Band Helical	8.1	203	RED	136-174MHz	NAD6563
VHF Helical	7.8 7.3 6.9	195 183 172	YELLOW BLACK BLUE	136-151MHz 151-162MHz 162-174MHz	NAD6566 NAD6567 NAD6568
UHF Helical	3.3 3.2 3.2	83 80 79	RED GREEN BLACK	403-435 MHz 435-470MHz 470-512MHz	NAE6546 NAE6547 NAE6548
UHF Wide Band Whip	5.2	130	GREY	403-512MHz	NAE6549
800MHz Whip	7	175	RED	806-870MHz	NAF5037
800MHz Dipole	8	200	RED	806-870MHz	NAF5039
800MHz Stubby, Quarterwave	3.3	83	WHITE	806-870MHz	NAF5042

### Attach the Antenna

With the radio turned off, turn the antenna clockwise to attach it to the radio.

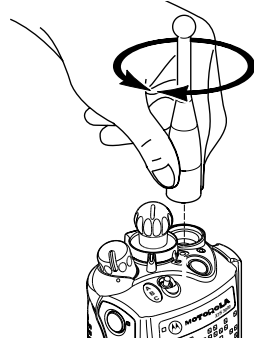

---

### Remove the Antenna

With the radio turned off, turn the antenna counter-clockwise to remove it from the radio.

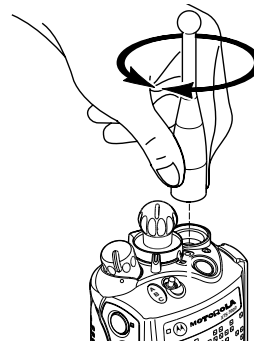

## Belt Clip

**Note:** The battery must be removed from the radio before the belt clip can be installed or removed.

### Attach the Belt Clip

- 1 Holding the battery in one hand so that the top of the battery faces upward and the back of the battery faces you, hold the belt clip in the other hand with its top facing upward.
- 2 Align the slide assembly on the front of the belt clip with the slots on the back of the battery. Slide the belt clip downward toward the bottom of the battery until the belt clip clicks in place.

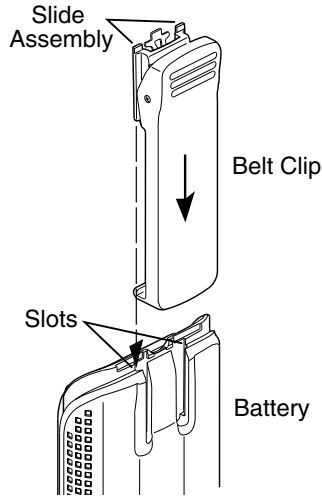

### Remove the Belt Clip

- 1 Hold the battery in one hand so that the top of the battery faces upward, and the front (radio side) of the battery faces you.
- 2 At the top of the battery, press down on the belt clip's metal tab and slide the belt clip upward. Continue to slide the belt clip upward until it is free from the battery.

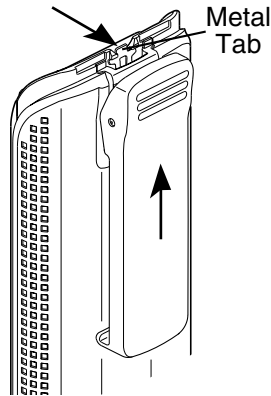



## Universal Connector Cover

The universal connector is located on the antenna side of the radio. It is used to connect accessories to the radio.

### Remove the Connector Cover



**Caution**

When the Universal Connector is not in use, keep it covered with the Universal Connector cover to prevent damage.

- 1 Turn the radio off.
- 2 *While holding the cover's top (flat) end in place with your thumb, pry upward on the cover's lower end until it disengages from the radio.*

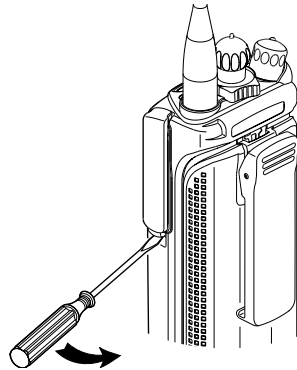

## Attach the Connector Cover

- 1 Turn the radio off.
- 2 Insert the top, hooked end of the cover into the top of the connector slot.

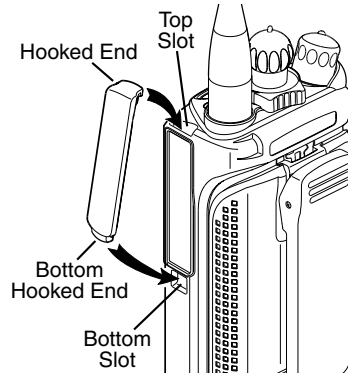

- 3 While holding the top end, swing the rounded end into place at the bottom of the connector. Press firmly until it snaps into place.

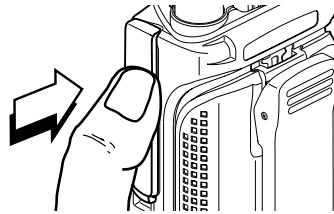

## XTS 3000 R Radios Only

**Note:** In XTS 3000 R radios, the “R” signifies the radio is a **Rugged**-type radio designed to withstand adverse field conditions such as being submersed in water.



### Caution

- The XTS 3000 R radio casting has a vent hole that allows for pressure equalization in the radio. Never poke this vent with any objects, such as needles, tweezers or screwdrivers. This creates a leak path into the radio and the radio’s submersibility is lost.
- The pressure equalization vent is located on the chassis, just below the battery contact. Never obstruct or cover the two slots with any object, including a label. Ensure that no oily substances come in contact with this vent.
- The XTS 3000 R radio is designed to be submersed to a maximum depth of 6 feet and a maximum submersion time of 4 hours. Exceeding either maximum limit may result in damage to the radio.

### Note:

- 1 If the radio has been submersed in water, shake the radio well to remove any water that may be trapped inside the speaker grille and microphone port. Otherwise, the water could cause decreased audio capabilities.
- 2 If the radio’s battery contact area has been exposed to water, dry and clean battery contacts on both the radio and the battery before attaching the battery to the radio. Otherwise, the water could short-circuit the radio.
- 3 If the radio has been submersed in a corrosive medium (such as salt water), rinse the radio and battery in fresh water and dry the radio and battery.
- 4 To clean the exterior surfaces of the radio, use a diluted solution of mild dish washing detergent and fresh water (one teaspoon of detergent to one gallon of water).

- 5 Do not disassemble the radio. This could damage radio seals and result in leak paths into the radio. Radio maintenance should be performed only by a qualified service person.
- 6 Elastomer technology materials used for seals in rugged portable radios can age with time and environmental exposure. Therefore, Motorola recommends that rugged radios be checked annually to assure the water-tight integrity of the radio. Radio disassembly and reassembly procedures and information regarding test equipment necessary to inspect, maintain and troubleshoot radio seals can be found in the XTS 3000 basic service manual.

# General Radio Operation

---

Your radio is ready for use once a fully-charged battery and antenna have been connected to the radio. Refer to page 3 to ensure a complete understanding of the radio's controls and indicators. If necessary, review the "Additional Information" section starting on page 75.

## Turning the Radio On and Off

### Turn the Radio On

Turn the **On/Off/Volume Control knob** *clockwise*. The radio performs a power-up self test during which the display briefly shows *Self Test*. When the radio passes the self test, a medium-pitched tone sounds. This tone is programmable by your system manager or radio technician using radio service software from Motorola.

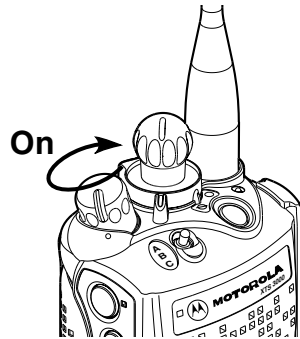

If the radio fails the self test, you hear a low-pitched tone and a numeric error code appears on the display. Turn off the radio, check the battery, and turn the radio on. If the radio fails the power-up test again, record the error code and contact your system administrator or an authorized radio technician.

### Turn the Radio Off

Turn the **On/Off/Volume Control knob** *counterclockwise* until you hear a click.

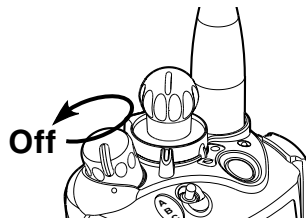

## Zones and Channels

A zone is a grouping of channels. A channel is a group of radio characteristics such as transmit/receive frequency pairs. After you turn your radio on, select the desired zone and channel.

### Selecting a Zone

- 1 Press  until the display shows the ZONE softkey. (The exact location of softkeys vary based upon individual radio programming.)

**OR**

Place the **Zone switch** (see page 4) in the desired position. This takes you directly to the result of the action specified in step 3.

- 2 Press  directly below ZONE.

The display shows the current zone name (flashing) and the channel name (on steady).

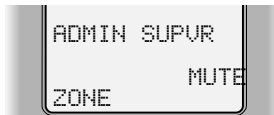

- 3 Press  until the desired zone name appears on the display.

**OR**

Using the alphanumeric keypad, enter the number of the desired zone.

**Note:** If the selected zone is not programmed, the display shows NOT PROGRAMMED until a valid programmed zone is selected. This does not mean your radio is not programmed; only that the zone you selected is not programmed.

- 4 To select the displayed zone/channel combination, press .

**OR**

To transmit on the displayed zone/channel combination, press the **PTT button**.

## Selecting a Channel

**Note:** Consult your service technician to determine which one of the following methods to use for channel selection.

### Method 1 Channel Selection

Method 1 Channel Selection is used when the **16-Position Select knob** is programmed for channel selection.

Once the desired zone appears on the display (step 4 of zone selection), rotate the preprogrammed **16-Position Select knob** to the desired channel. The new name appears on the display.

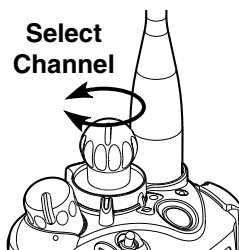

### Method 2 Channel Selection

Method 2 Channel Selection is used when a softkey is programmed for channel selection.

- 1 Press until the display shows the CHAN softkey.

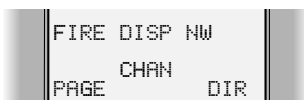

- 2 Press directly below CHAN.

The display shows the zone name (on steady) and the current channel name (flashing).



- 3 Press until the desired channel name appears on the display.

**OR**

Using the alphanumeric keypad, enter the number of the desired channel.

**Note:** If the selected channel is not programmed, the display shows NOT PROGRAMMED until a valid programmed channel is selected. This does not mean your radio is not programmed; only that the channel you selected is not programmed.

4 To exit the channel selection menu, press .

**OR**

To transmit on the displayed zone/channel combination, press the **PTT button**.

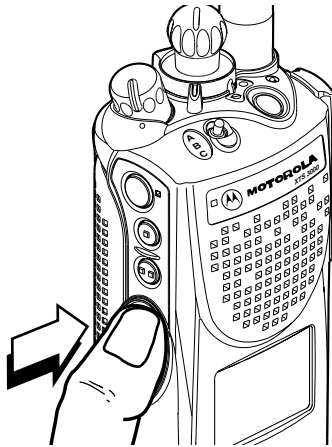

## Transmitting and Receiving

**Note:** Radio users who switch from analog to digital radios often assume that the lack of static on a digital channel is an indication that the radio is not working properly. This is not the case. Digital technology quiets the transmission by removing the noise from the signal and allowing only the clear voice or data information to be heard.

This section emphasizes the importance of knowing how to monitor a channel for traffic before keying up to send a transmission.



## Without Using Volume Set and Monitor Buttons

- 1 Select the desired zone/channel.
- 2 Listen for ongoing conversations; if the channel becomes clear, proceed to step 3.
- 3 Press and hold the **PTT button** to transmit and wait for the Talk Permit tone (a group of medium-pitched tones). The LED lights red. When speaking, keep the microphone one to two inches from your mouth.

**Note:** If you do not hear a Talk Permit tone, your system administrator has preprogrammed the tone to be off.

## Use the Preprogrammed Volume Set Button

- 1 Turn the radio on and select the desired zone and channel.
- 2 To hear the volume set tone, press and hold the **Volume Set button**.
- 3 Adjust the **Volume Control knob** if necessary.
- 4 Release the **Volume Set button**.
- 5 To transmit, press and hold the **PTT button** and release it to listen. The LED lights RED while transmitting.

## Use the Preprogrammed Monitor Button

- 1 Turn the radio on and select the desired zone and channel.
- 2 To listen for activity, press the preprogrammed **Monitor button** (see page 4).

**Note:** If the channel on which you are transmitting is programmed to receive Private-Line<sup>®</sup> (PL), ensure that the channel is not in use by momentarily pressing the preprogrammed **Monitor button** (see page 4) to listen for activity. To put the radio in permanent monitor operation (squelch defeat), press and hold the preprogrammed **Monitor button** for five seconds (programmed by your system administrator or radio technician). To return the radio to its original squelch state, tap the **Monitor button** again or press the **PTT button**.

If you try to transmit on a channel that is programmed for receive only, an invalid tone sounds until you release the **PTT button**.

- 3** Adjust the **Volume Control knob** if necessary.
- 4** Press and hold the **PTT button** to transmit and release it to listen. The LED lights RED while transmitting.

## Using Lists

The list feature on your radio allows you to store commonly used numbers with an identifiable name. For example, the telephone feature has an associated list of names and telephone numbers.

The following general operations are available using lists:

- a preprogrammed list can be viewed,
- a number in a list can be changed,
- a specific member in a list can be selected.

## Viewing a List

1 Press **▶** until the display shows the **VIEW** softkey.

**Note:** The exact location of softkeys vary based upon individual radio programming.

2 Press **⊖** directly below **VIEW**.

3 The display shows available lists (example: **PAGE**, **PHON**, **CALL**); use **◀** or **▶** to see other available lists

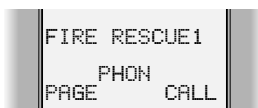

4 Press **⊖** directly below the list you wish to view. For example, to view the list of telephone numbers stored in your radio, press **⊖** directly below **PHON**.

5 The display shows the first member in the list (name on the upper line, number on the lower line). The steady **█** status indicator appears indicating you are in view mode.

## Changing a List

**Note:** Only numbers can be changed or reprogrammed in a list. Names on a list can be changed by your system administrator or radio technician.

If your radio is programmed to use the scan feature, refer to page 56 for information on changing the scan list.

1 Press **▶** until the display shows the **PROG** softkey.

**Note:** The exact location of softkeys will vary based upon individual radio programming.

2 Press **⊖** directly below **PROG**.

The display shows the lists that can be changed (PAGE, PHON, CALL, etc.).

- 3 Press  $\ominus$  directly below the list you wish to change. For example, to change a telephone number press  $\ominus$  directly below PHON.

The display shows the first member in the list (name on the upper line, number on the lower line). The flashing  $\square$  status indicator appears, indicating you are in the programming mode.

- 4 To locate the member's number you wish to change, press  $\leftarrow$  or  $\rightarrow$  to scroll through the list.

**OR**

To go directly to a specific member in the list, enter the number (1-19) that corresponds to that member's placement in the list.

The display shows the member's name on the upper line and the number on the lower line.

- 5 To edit the member's number, press the **Select button**.
- 6 To edit the member's number, press any of the numeric keys (0) through (9) and special function keys (\*, #).

The blinking cursor indicates the position of the next number to be added.

The cursor disappears when the maximum amount of characters have been added. The maximum amount of characters allowed for a telephone number is 16 and 8 for an ID number.

If you try to add any more digits, you hear an invalid tone.

- Note:** In the number-edit mode,  $\leftarrow$  functions as a backspace key. To erase the previously entered digit on the display and move the cursor to the left, press this key. If you erase the entire number, and continue to press  $\leftarrow$  or press  $\rightarrow$ , the radio exits the number-edit mode and returns to step 4.

**Note:** Some telephone systems require a pause to be entered as part of the number dialed (for example, dialing “9” to access an outside line). To enter a pause in the number (shown as a “P” on the display), press **\*** followed by **#**.

- To save your changes, press the **Select button**. This returns you to the list (step 4) and you can make any additional changes as necessary.

**OR**

To cancel the change, press **HOME**. The radio exits reprogramming mode and returns you to the home display without modifying the list.

## Selecting From a List

- Press **RIGHT** until the display shows the desired feature as a softkey.  
For example, to select from the telephone list stored in your radio, press **RIGHT** until the display shows the **PHON** softkey. The exact location of softkeys are programmed by your system administrator or radio technician.
- Press **DOWN** directly below the desired feature. Using the same example in step 1, press **DOWN** directly below **PHON**.
- The display shows the last telephone number dialed or the last ID number transmitted/received. The **LIST** softkey also appears.

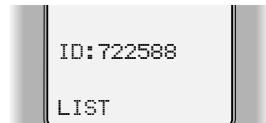
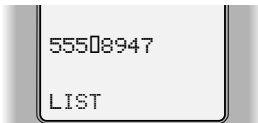

- To access the preprogrammed list, press **DOWN** directly below **LIST**.
- Scroll through the preprogrammed list by pressing **LEFT** or **RIGHT** until you locate the desired member's name/number.

**OR**

To go directly to a specific member in the list, enter the number using your alphanumeric keypad (1 through 19) that corresponds to that member's placement in the list.

**Note:** If you are using the telephone feature (PHON), a call is made to the displayed number when you press the **PTT button**.

The display alternately shows the name and number (phone or ID) of a member in the list.



**Note:** Press **⊖** directly below the LNUM softkey to access the **Last** telephone **NUMBER** dialed or the **Last ID NUMBER** transmitted/received.

## General Radio Features

### Radio Lock (Non-Secure Radios)

The radio-lock feature enables you to select a unique numeric password. If the feature is enabled, the display shows **RADIO LOCKED** when the radio is turned on.



This feature is programmed by your system administrator or radio technician.

- 1 Turn your radio ON.
- 2 Enter your numeric password (1 to 8 characters).

As you enter the password digits, the display shows dashes.

If a digit mistakenly entered, **⊖** functions as a backspace key. Once the correct password is entered, the radio unlocks.

To change your password:

- 1 Press  until the display shows the **PSWD** softkey.
- 2 Press  directly below **PSWD**.  
The display shows **OLD PASSWORD**.
- 3 Enter the current password.
- 4 If the password entered is correct, the display shows **NEW PASSWORD**.
- 5 Enter the new password and press the **Select** button.

**Note:** If you forget the numeric password, you must have the radio's coreplug replaced by a qualified service technician and a new password programmed at that time by your system administrator or radio technician.

## Radio Lock (Secure Radios Only)

This feature changes your radio to a more robust security system that protects the use of the secure encryption keys. If your radio is preprogrammed to include this feature, the display shows **RADIO LOCKED** when you turn the radio on.

This feature is programmed by your system administrator or radio technician.

- 1 Turn your radio ON.
- 2 Enter your numeric password (1 to 8 characters).  
As you enter the password digits, the display shows dashes.  
In the event you make a mistake,  functions as a backspace key. Once the correct password is entered, the radio unlocks.
- 3 Press the **Select button**.
- 4 If the password is correct, the radio unlocks.

**OR**

If the password is incorrect, the radio remains locked. If the wrong password is entered three times, the display shows **DEAD**

LOCKED and you must turn the radio off and on again in order to enter another password.





If you enter a total of 15 consecutive incorrect passwords (turning the radio on and off does not reset the number of incorrect tries), the radio automatically erases all of its encryption keys and the display shows RADIO LOCKED.

**Note:** If you forget the password or enter an incorrect password 15 or more times, enter in eight asterisks (\*\*\*\*\*\*) and press the **Select button** (see page 2).

This action:

- unlocks your radio,
- erases all encryption keys, and
- the password will revert to the factory default password of 01234567.

To change your password:

- 1 Press  until the display shows the PSWD softkey.
- 2 Press  directly below PSWD.  
The display shows OLD PASSWORD.
- 3 Enter the current password.
- 4 If the password entered is correct, the display shows NEW PASSWORD.
- 5 Enter the new password and press  directly below SEL.  
The display shows CONFIRM.
- 6 Re-enter the new password and press  directly below SEL.
- 7 If the two new passwords match, the radio unlocks.

**OR**

If the two new passwords do not match, the display shows NEW PASSWORD. This takes you to the result of the action described in step 3.



**Note:** You cannot change your password if you enter three incorrect old passwords. The radio exits the radio-lock feature and will not allow you to press the **PSWD** softkey until the radio is turned off and on again.

## Radio-Lock Enable/Disable (Secure Radios Only)

This feature allows you to enable/disable the radio-lock feature using the radio's alphanumeric keypad.

This feature is programmed by your system administrator or radio technician.

To enable or disable the Radio-Lock feature:

- 1 Press **▶** until the display shows the **LOGF** softkey.
- 2 Press **⊖** directly below **LOGF**.
- 3 The display shows the current password state. **PSWD ENABLD** indicates that the Radio-Lock feature is enabled and **PSWD DISBLD** indicates that Radio-Lock feature is disabled.
- 4 To enable the Radio-Lock feature, press **⊖** directly below **ENAB**.

**OR**

To disable the Radio-Lock feature, press **⊖** directly below **DSAB**.

## Muting the Keypad Tones



The radio's keypad tones, normally heard each time a keypad key is pressed, can be turned off (muted) or on (not muted) at your discretion. You can mute the tones using a preprogrammed switch if applicable or using the softkey.

To mute keypad tones using the **Keypad-Mute switch**:

To turn the keypad tones off, put the **Keypad-Mute switch** in the "tones off" position.

To turn the keypad tones on for normal operation, put the **Keypad-Mute switch** in the "tones on" position.

To mute keypad tones using the softkey feature:

- 1 Press  until the display shows the MUTE softkey.
- 2 Press  directly below MUTE.
- 3 The display shows the current mute state. TONES ON indicates tones are not muted and TONES OFF indicates tones are muted.

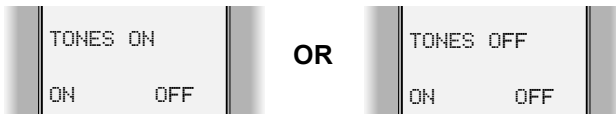

- 4 Press  below the desired mute state (ON or OFF).

**Note:** Press  or the **PTT button** to exit this menu without modifying the existing setting.

## Time-Out Timer

The new ASTRO portable radio is equipped with a programmable time-out timer which, upon expiration, turns off the transmitter. This timer is programmable by your system manager or service technician and can be set from 0 seconds (off) to 7.75 minutes (465 seconds), at 15-second increments. ASTRO radios have been programmed at shipment with a default time-out timer duration of 60 seconds.

A time-out timer warning occurs approximately four seconds before the allocated time-out timer expires. The warning is a short, low-pitched tone.

If the **PTT button** is held down longer than the time-out timer's allotted time, a continuous, low-pitched tone sounds and the LED stops lighting red, indicating that your transmission has been cut off. This tone continues to sound until the **PTT button** is released.

- 1 Release the **PTT button** to silence the warning.
- 2 To transmit another message, press the **PTT button**.

## Low-Battery Indication

If the battery voltage falls below the low-voltage level, a flashing  status indicator appears on the display

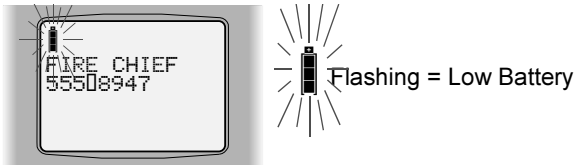

If a low-battery indication occurs, replace the battery.

Your system administrator may have programmed your radio to indicate a low-battery status in one of the following ways:

- When the **PTT button** is pressed, the bi-color LED blinks red to indicate a low-battery condition.
- When the **PTT button** is released following a transmission, you hear a short, high-pitched tone (chirp) to indicate a low-battery condition.
- When the radio is in the standby mode and a low-battery condition occurs, you hear an alert tone for 30 to 930 seconds at 30-second increments. This duration is programmed by your system administrator or radio technician.

## Keypad Lock

The Keypad Lock feature allows you to lock and unlock the radio keypad as necessary by pressing the preprogrammed button or moving the preprogrammed switch to the locked position (see page 4). This feature is programmed by your system administrator or radio technician.

**Note:** If the Keypad Lock feature is programmed to a switch and the switch is moved to the ON position, Keypad Lock remains on after powering off and on again. If the Keypad Lock feature is assigned to a button, default settings are restored when the radio is turned off.

## Channel Selector Lock

Channel Selector Lock allows you to lock the radio on one channel in order to prevent unintentional channel changes. This feature is only available if Keypad Lock is enabled.

- 1 Select a channel (see page 23 for instructions on selecting a channel).
- 2 Press the preprogrammed **Channel Lock button** or move the preprogrammed **Channel Lock switch** to the locked position (see page 4).

Once the Channel Selector Lock feature is ON, you hear a chirp tone if you try to change the channel.

**Note:** If the Channel Selector Lock feature is programmed on a switch and the switch is set to ON, the radio channel remains locked after powering off and on again.

To unlock the channel selector, adjust switch to the OFF position or press the preprogrammed button again.

**Note:** The Channel Selector Lock does not block a channel change command such as in the event of Dynamic Regrouping.

# Common Radio Features

---

## Conventional Squelch Options

Tone Private Line (PL), Digital Private-Line (DPL), network ID, and carrier squelch operations are all available in the same radio on a per channel basis.

**Note:** Network ID is only available on ASTRO digital channels consult your service technician for details.

In carrier squelch operation, all traffic on the channel is heard. However, in PL, DPL, or network ID operation, your radio responds only to those messages intended for you. PL, DPL, network ID, and carrier squelch can be programmed for each channel.

Whenever the radio is operating in carrier squelch mode, the display shows the  status indicator.

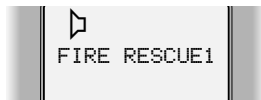

 On Steady = Carrier-Squelch Operation

## Project 25 Digital Squelch Options

Each conventional personality may be programmed by your system administrator or radio technician for one of the following squelch options in digital mode:

<b><i>Digital Carrier-Operated Squelch (COS)</i></b>	This option allows the radio to respond to any received digital Project 25 signal.
<b><i>Normal Squelch</i></b>	This option allows the radio to respond to any digital Project 25 signal that has the correct Network access code.
<b><i>Selective Squelch</i></b>	This option allows the radio to respond to any digital Project 25 signal that has the correct Network access code and the correct talkgroup.
<b><i>Data and Squelch</i></b>	This option allows the radio to respond to any digital Project 25 signal that has the correct Network access code and is addressed to a specific radio. The radio responds to selective calls only.

## Non-Project 25 Digital Squelch Options

Each conventional personality may be programmed for one of the following squelch options in digital mode (consult your service technician).

<b>No Squelch</b>	This option allows the radio to respond to any ASTRO digital signal that has the correct Network access code.
<b>Data or Squelch</b>	This option allows the radio to respond to any ASTRO digital signal that has the correct Network access code and the correct talkgroup.
<b>Data and Squelch</b>	This option allows the radio to respond to any ASTRO digital signal that has the correct Network access code and is addressed to a specific radio (the radio responds to selective calls only).

## Data Calls (Status Calls or Message Calls)

This feature allows you to send data calls (status calls or message calls) from your radio to the dispatcher to indicate a predefined condition. Each defined status or message can have a 12-character alias. You can have a maximum of conditions 16 pre-defined message conditions, 16 pre-defined status conditions for conventional and 8 pre-defined status conditions for trunking.

### Sending a Status Call or Message Call

1 Press **▶** until the display shows the **STS** or **MSG** softkey,

**OR**

Press the preprogrammed **Status button** or **Message button** (see page 4). This takes you to the result of the action described in step 2.

2 Press **⊖** directly below the type of data call you wish to make.

The last acknowledged status call or the first message in the message list is displayed.

**Note:** If no status has been acknowledged, the first status in the status list is displayed.

- 3 Press ◀ or ▶ to scroll through the list until you locate the predefined status you wish to send.
- 4 When you locate the appropriate status, press the **PTT button**.
- 5 Upon receipt of the data call, the dispatcher transmits an acknowledgement to your radio. Your radio beep four times, displays `ACK RECEIVED`, and returns to normal dispatch operation.

If the system does not acknowledge the data call, the display alternately shows `NO ACKNOWLEDG` and the currently selected predefined condition.



- 6 Press **HOME** to exit the data call feature and return to the home display.

**Note:** While the data call feature is selected, you do not hear normal radio communication on trunked channels.

If the data call feature (`STS` or `MSG`) is selected and no activity occurs for six seconds, you hear an alert tone indicating that the data call feature is active. The alert tone stops when **HOME** or the **PTT button** is pressed.

## Emergency State

Your radio may have been programmed by your system administrator or radio technician with the Emergency State feature.

Press the preprogrammed **Emergency button** (see page 4) to send out an emergency signal that takes precedence over any other signalling activity in progress on the selected channel. There are two types of emergency signals:

- Emergency Alarm sends a data transmission to alert the dispatcher to an emergency condition and identifies the radio sending the emergency signal.

- Emergency Call is a type of dispatch operation that gives your radio priority access to channels. This feature is not available on conventional radios.

**Note:** Entering Emergency State signals a critical situation. It should never be used for any other reason.

If you change channels during emergency operation, the emergency alarm or call is moved to, and continue on, the new channel if the new channel is also programmed for emergency operation. If the new channel is not programmed for emergency operation, you hear a continuous, low-pitched invalid mode tone until the radio exits emergency state or you change to a channel programmed for emergency operation.

For emergency-alarm with emergency-call signals, once an acknowledgment is received from the dispatcher, your radio enters emergency call state.

While your radio is in emergency-call state, it operates in the usual dispatch manner or returns to one of the following operations if programmed to do so:

- Tactical/Non-Revert Operation — you talk on the channel selected before entering the emergency state.
- Non-Tactical/Revert Operation — you talk on a preprogrammed emergency channel, and the emergency alarm is sent to this preprogrammed emergency channel.

## Entering the Emergency State

- 1 Press and hold the preprogrammed **Emergency button** (see page 4). The length of the press-and-hold time required is programmed by your system administrator or radio technician.
- 2 The display alternately shows `EMERGENCY` and the current zone/channel combination (except during silent emergency alarm).



When you receive the dispatcher's acknowledgment, the display shows `ACK RECEIVED`, four tones sound, the alarm ends, and the radio exits the emergency mode. If no acknowledgment is received, the display shows `NO ACKNOWLEDG`, the alarm ends, and the radio exits the emergency mode.

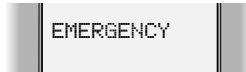

During emergency alarm state:

- The display alternately shows the current zone/channel and `EMERGENCY`,
- The LED lights red, and
- You hear a group of short, medium-pitched tones.

**Note:** If the selected channel does not support emergency, the display shows `NO EMERGENCY`. Select a channel that is programmed for emergency calls.

During a silent-emergency call:

- The display does not light.
- You do not hear tones.
- The display does not change.
- The audio is muted (turned off) and remains so until you exit the emergency alarm state, and
- The silent-emergency state continues until you press the **PTT button**.

During an emergency call, press the **PTT button** to cancel the alert.

## Exiting the Emergency State

It is important that you exit emergency state when it is no longer necessary.

- 1 To exit Emergency State, press the preprogrammed **Emergency button** for approximately one second.

This duration is programmed by your system administrator or radio technician.

The way you exit Emergency State may vary based on how your radio was programmed by your system administrator or radio technician.

If your radio is programmed for emergency alarm,

Press the **PTT button**. The alarm is cancelled (without an emergency-exit tone), and you may begin transmitting your voice call.

**OR**

If your radio is programmed for emergency alarm with call,

**press** the **PTT button** while the radio is in emergency-alarm operation to place the radio in emergency-call operation.

If your radio is programmed with emergency alarm only, the radio automatically exits emergency state after receiving an acknowledgment from the dispatcher or if the alarms are exhausted when no acknowledgment is received. This method applies to non-silent emergency alarm radios.

**Note:** If your radio is programmed for silent-emergency, your radio does not automatically exit Emergency State. One of the above methods must be used.

## Emergency Keep-Alive

When this feature is enabled, moving the **On/Off Control knob** to the off position does not turn your radio off if it is in an emergency state. Your radio continues normal emergency operation as if the power is on. The radio will not turn power off until it exits emergency state.

## Emergency Channel Selector Lock

When this feature is enabled, your radio Channel Selector is automatically locked upon entering Emergency State preventing the channel from being changed during an emergency. Upon exiting Emergency State, the channel remains on the channel selected prior to entering Emergency State.

This feature is only available if the Channel Selector Lock feature is programmed by your system administrator or radio technician (see page 4).

## Talkgroup Calls (Project 25 Radios Only)

Project 25 replaces Motorola's group selective calls with talkgroup calls. This feature allows you to define talkgroups for your conventional system. Talkgroups, combined with selective squelch operation, allow groups of users to transparently share a conventional channel. Talkgroups may be slaved to a personality by your system administrator or you may select them.

Encryption keys are slaved to talkgroups. When talkgroups are enabled, encryption keys are changed by changing the active talkgroup.

## Talkgroup Selection

- 1 Press **▶** until the display shows the TGRP softkey.
- 2 Press **⊖** directly below TGRP.

The display shows the last user-selected-and-stored talkgroup and the available softkey selections.

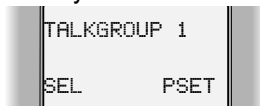

- 3 Press **◀** or **▶** to scroll through the talkgroups.

**OR**

Enter the number of the desired index.

- 4 To select the preset or programmed talkgroup, press  directly below PSET.

**OR**

To save the currently displayed talkgroup and return to the home display press  directly below SEL.

If the encryption key slaved to the new talkgroup is erased, the display shows `KEY FAIL` and you hear a group of medium-pitched tones.

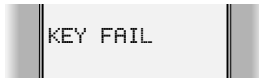

If the encryption key that is slaved to the new talkgroup is not allowed, the display shows `ILLEGAL KEY` and you hear a momentary tone.

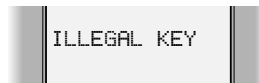

- 5 Press  or the **PTT button** or turn the **16-Position Select knob** to exit this menu.

## Individual Calls

Individual calls are defined as follows:

<b><i>Telephone Calls</i></b>	Similar to standard telephone calls, except you use your radio. These can be landline-to-radio or radio-to- landline calls.
<b><i>Private-Conversation™ II Calls (Private Calls) (Trunked Channels Only)</i></b>	One-on-one calls involving two specific radios in which the conversation is not heard by others in the current radio talkgroup.
<b><i>Enhanced Private-Conversation Calls (Enhanced Private Calls) (Trunked Channels Only)</i></b>	Same as Private Conversation II calls except the radio automatically verifies that the target radio is active on the system. The target radio user can also view the ID of the calling radio before answering.
Selective Calls (Conventional Channels Only)	Used to selectively call an individual radio on Project 25 systems, or an individual radio or group of radios on non-Project 25 systems. It is intended to provide privacy and to eliminate the annoyance of having to listen to conversations that are of no interest to you.
Call-Alert™ Pages	Your radio functions like a pager; Call Alert pages provide a means to signal other radio users that you wish to get in touch with them (even if they are away from their radio or in a noisy environment). Call Alert pages also allow you to verify that the radio they are calling is active on the system.

**Note:** In the following procedures, any reference to Private-Conversation (Private Call) represents both Private-Conversation II calls and Enhanced Private-Conversation calls, unless otherwise specified.

## Selecting the Individual Call Feature

**Note:** On conventional channels, you must monitor the channel for activity before making an individual call (see page 25 for details).

- 1 For a telephone call, press  until the display shows PHON,



**OR**

For a Private-Conversation Call or a Selective Call, press  until the display shows CALL,

For a Call-Alert Page, press  until the display shows PAGE.

**OR**

If your radio has been programmed by your system administrator or radio technician for quick access (or one-touch), press the designated button for either the Phone, Private Call, Selective Call, or Call Alert feature. This takes you directly to the result of the action specified in step 2.

- 2 Press  directly below the desired softkey feature. For example, to make a telephone call, press  directly below PHON.

The display shows the last telephone number dialed or the ID number of the last call/page transmitted/received.

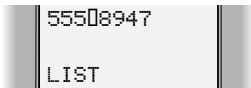

**OR**

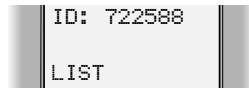

## Using the Individual Call Feature

With regard to telephone calls, your radio may be programmed by your system administrator to automatically access the telephone system in one of four ways:

Immediate Access	If your radio is programmed for Immediate Access and you access the Phone function (through a softkey or using a preprogrammed button), the radio tries to access the telephone system. The display shows <code>PLEASE WAIT</code> . If the attempt is successful, you hear a dial tone. The display shows the last number dialed.
Auto-Access (Conventional Channels Only)	Your radio may be programmed to auto-access the telephone system via a radio-to-landline phone patch during Conventional operation.
Manual Access (Conventional Channels Only)	If your radio is programmed for Manual Access, to access the telephone system via a radio-to-landline phone patch, enter a special telephone system access code using your alphanumeric keypad.
Delayed Access	If your radio is programmed for Delayed Access, enter a new phone number or ID number using your alphanumeric keypad and press the <b>PTT button</b> to send.

- 1 If the display shows `NO PHONE` or you do not hear a dial tone in any of the above situations, press  or the designated quick-access button (Phone, Private Call, Selective Call, or Call Alert button) to end the call.

If the display shows `PHONE BUSY`, your call is placed in queue until a line is available. When a line becomes available, the display shows `PLEASE WAIT` and a dial tone is heard.



- 2 If the party you are calling answers the call, press the **PTT button** to talk and release it to listen.

**Note:** After reaching the number you are calling, you may need to dial an extension number before you can reach your party.

Radios operating on trunked systems generate a high-pitched tone when the **PTT button** is released. This is heard by the landline party and is an indicator to begin talking.

- When you have finished your conversation, or if the display shows NO PHONE or NO ACKNOWLEDG, disconnect by pressing  or the **Phone button**. The radio returns to the home display.

## Calling the Last Number Dialed or Last ID Number Transmitted/Received

<b><i>For Telephone Calls Only</i></b>	Press the <b>PTT button</b> . You hear either ringing or a busy tone. On a trunking system, if you hear a busy tone, press the <b>PTT button</b> to try again. Otherwise, press  to exit the Telephone Call feature.
<b><i>For Private-Conversation Calls Only</i></b>	Press the <b>PTT button</b> . Begin talking.
<b><i>For Enhanced Private-Conversation Calls Only</i></b>	Press the <b>PTT button</b> . If the radio you are calling is in service, you hear ringing and, if the target-radio user responds to the call, the individual's voice.
<b><i>For Selective Calls</i></b>	Press the <b>PTT button</b> . Begin talking.
<b><i>For Call-Alert Pages Only</i></b>	Press the <b>PTT button</b> . If the page is accepted, you hear four beeps, the display shows ACK RECEIVED, and the radio returns to the home display. If the page is not accepted, the display shows NO ACKNOWLEDG; press the <b>PTT button</b> to try again or press  to exit the Call Alert Page feature.



## Calling a Number From a List

Use the List feature to select a specific number from your radio's memory list:

- 1 Scroll through the list by pressing ◀ or ▶ until you locate the member's number you wish to call.

### OR

To go directly to a specific member in the list, enter the number (1 through 19) that corresponds with that member's placement in the list.

- 2 Press the **PTT button**.

If the system does not acknowledge the call, your radio alternately displays NO ACKNOWLEDG and the currently selected number.

## Calling a New Number

This feature is programmed by your system administrator or radio technician.

- 1 Enter a new telephone number using your alphanumeric keypad (1 through QWERTY).



The display shows a cursor appears indicating the position of the next number to be added.

When the maximum number of characters are entered (sixteen on non-Project 25 radios or 34 on Project 25 radios for a telephone number, six for a trunking ID number and four for a conventional MDC ID number or 8 for a conventional ASTRO ID number), the cursor disappears. If you try to add more digits, you hear an invalid tone.

- 2 Press the **PTT button**.

**Note:** This action does not program a new number in your radio's memory list.

Your radio may be programmed for either live dial or buffered dial. Live dial sends out each digit as the key is pressed, similar to a regular desktop telephone. Buffered dial requires that you enter all digits and press the **PTT button**. Consult your system administrator or radio technician for details.

To enter a pause in the number, press  followed by . A "P" appears on the display.

To erase incorrect characters,  functions as a backspace key.

## Answering an Individual Call

- 1 When an individual call is being received, you hear and/or see:
  - a telephone-type ringing if it is a telephone call;
  - two alert tones if it is a Private-Conversation call or Selective call;
  - a continuous cycle of four tones if it is a Call-Alert page;
  - a blinking green signal on the LED;
  - the  indicator flashing;
  - and the display shows one of the following:



- 2 Telephone Calls Only — Press the **Call Response button**.

**OR**

Private-Conversation Calls and Call-Alert Pages with Private-Conversation — Within twenty seconds, press the **Call Response button**.

The display shows the caller's ID number. Press the **PTT button** to talk privately.

Selective Call — The display remains active for two seconds and then the speaker is no longer muted.

**OR**

Call-Alert Pages Only — To see the caller's ID, press the **Select button**.

If you wish to respond, press the **PTT button** and your conversation is heard by the entire talkgroup.

- 3 Press the **PTT button** to talk and release it to listen.
- 4 When you have finished your conversation, disconnect by pressing . The radio returns to the home display.

## PL Defeat

The PL defeat feature allows you to override any coded squelch (DPL, PL, or network ID) that may be programmed to a channel. To activate this feature, place the preprogrammed **PL Defeat switch** if applicable (see page 4) in the PL Defeat position. You are able to hear any activity on the channel; if no activity is present, the radio is muted.

## Repeater Access

Repeater access allows you to selectively activate repeaters, which is especially useful in areas where repeaters are placed close together to ensure total coverage. Repeater access can operate automatically or manually and can be enabled or disabled by your system administrator or radio technician for specific channels as required. During automatic repeater access, you hear a sidetone to indicate that the repeater access code is being transmitted to discourage you from talking over the data transmission.

In radios programmed with manual repeater access, you can activate the repeater access code transmission by pressing the preprogrammed **Repeater Access button** if your radio has one (see page 4). You do not hear a sidetone. On radios with MDC-1200™ signalling, when the repeater access is acknowledged, the radio

sounds an acknowledge alert tone. The acknowledge alert tone can be programmed by your system administrator or radio technician.

## Repeater/Direct

The repeater/direct feature allows you to bypass the repeater and talk directly to another radio. This is known as DIRECT operation or talkaround operation. The transmit frequency is the same as the receive frequency.

In REPEATER operation, you talk through the repeater, which increases the radio's operating range. The transmit frequency is not the same as the receive frequency.

### Selecting Repeater or Direct Operation

- 1 Press  until the display shows DIR.

**OR**

Place the preprogrammed **Repeater/Direct switch** (see page 4) in the repeater position or the direct position.

- 2 Press  directly below DIR.

The display shows the current operation for a few seconds and then the two possible operations.

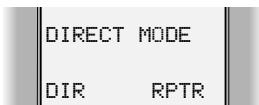

**OR**

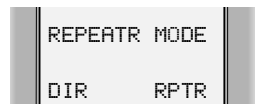

- 3 Press  below the desired softkey (DIR or RPTR).

**Note:** Press  or the **PTT button** to exit the menu without changing the existing setting.

## Scan

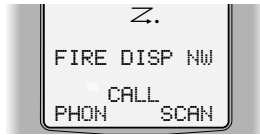

Scanning allows you to monitor different channels automatically through the use of scan lists. If there is activity on a channel, the Scan feature automatically takes you to that channel.

Each radio can have up to twenty unique scan lists. These scan lists are programmed by your system administrator or radio technician either manually or using radio service software.



Three types of scan lists are available (consult your service technician for additional information):

<b><i>Trunking Priority Monitor</i></b>	Comprises channels that are all from the same trunking system (10 different channels maximum). This feature only works on systems that support it.
<b><i>Conventional</i></b>	Comprises only conventional channels (15 different channels, maximum).
<b><i>Talkgroup Scan</i></b>	Comprises conventional and trunked channels from more than one trunking system (10 different channels maximum). Priority operation is not available in this type of list.

There are also several types of scanning available:



<p><b>Priority 1 Scanning</b></p>	<p>With Priority 1 scanning enabled, one member of the scan list is chosen as the Priority 1 member. Any activity on the Priority 1 channel is heard on the speaker even if another channel in the scan list has activity on it.</p>
<p><b>Priority 2 and Non-Priority Scanning</b></p>	<p>In addition to the Priority 1 channel being the number one priority, a second channel can be assigned as a Priority 2 channel, if desired. The remaining members in the scan list can be programmed as non-priority members of the scan list.</p>
<p><b>Automatic Scanning (Autoscan)</b></p>	<p>With this feature, the radio begins scanning whenever you select a channel to which a scan list is assigned (strapped). The radio continues auto scanning until you select a channel that does not have autoscan enabled.</p>
<p><b>Operator-Selectable Scan</b></p>	<p>Scan can be programmed by your system manager or service technician to be activated by a softkey related button or a Scan On/Off switch (see page 4).</p>

### Turning Scan On and Off

- 1 Press  until the display shows SCAN.
- 2 Press  directly below SCAN.

The display shows the current scan state.



- 3 Press  below the desired scan state (ON or OFF). When the scan feature is on (active), the display shows the scan indicator .

**Note:** Press  or the **PTT button** to exit this menu without changing the current setting.

## Deleting Nuisance Channels

When the radio scans a channel that you do not wish to hear (nuisance channel), you can temporarily delete the channel from the scan list.

- 1 When the radio is locked onto the channel to be deleted, press the **Nuisance-Delete button** (see page 4). Repeat this step to delete additional nuisance channels.

**Note:** Priority channels and the selected channel cannot be deleted using the nuisance-delete feature.

The radio continues scanning the remaining channels in the list. To resume scanning the deleted channel, you can change channels or exit and re-enter scan operation.

## Dynamic Priority Change (Conventional Operation Only)

While the radio is scanning, the dynamic priority change feature lets you *temporarily* change any channel in a scan list (except the Priority 1 channel) to the Priority 2 channel. The present Priority 2 channel becomes a non-priority channel. This change remains in effect until scan is turned off. Scanning then reverts to the preprogrammed state.

To change a channel to a Priority 2 channel:

- 1 Press the preprogrammed **Dynamic Priority button** (see page 4) when the radio is locked onto the channel to be designated as a Priority 2 channel.

**Note:** The Priority 1 channel cannot be changed to Priority 2 channel.

- 2 The radio continues scanning the remaining channels in the list. To resume scanning the preprogrammed Priority 2 channel, you must exit and re-enter scan operation.

## Viewing a Scan List

The View Scan List feature allows you to view the members of the scan list associated with the currently selected channel. You view a scan list the same way you view other lists (see “Viewing a List” on page 27).

## Programming a Scan List

- 1 Press **▶** until the display shows the **PROG** softkey.
- 2 Press **⊖** directly below **PROG**.

The display shows the lists (**PHON**, **CALL**, **SCAN**, etc.) that can be changed; use **◀** or **▶** to see other available lists.

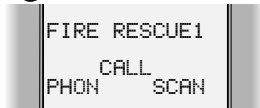

- 3 Press **⊖** directly below **SCAN**.

The display shows the first member in the list. The display shows a flashing **□** status indicator, indicating you are in the programming mode.

- 4 Press **⊖** below **SEL** to add the currently displayed channel to the scan list.

**OR**



Press **⊖** below **DEL** to delete the currently displayed channel from the scan list.

**OR**



Press the **Select button** (the **Top Side button**) to change the scan-list status of the currently displayed channel.



**Note:** Each press of the **SEL** softkey-related button, or the preprogrammed **Select button** (the **Top Side button**), causes one of the following to occur:

- The display shows the scan indicator (  ), indicating that this channel has been added to the scan list.
- The display shows a flashing “♦” next to the scan indicator (  ) indicating that this channel is the Priority 1 channel.
- The display shows a steady “♦” next to the scan indicator (  ) indicating that this channel is the Priority 2 channel.

The scan indicator turns off to indicate that this channel has been removed.

- 5 Use  or  to select additional channels to be added or deleted.

**OR**

To go directly to a channel number to be added or deleted from the list, enter the number using your alphanumeric keypad.

**OR**

Rotate the **16-Position Select knob** to select additional channels to be added or deleted.

- 6 Press  to exit programming mode.

**Note:** The following notes may apply depending on how your radio is programmed by your system manager or service technician.

- A maximum of 16 channels can be added to the scan list (including the selected channel). If you try to add more than 16 channels to the scan list, the radio sounds an invalid tone to indicate the scan list is full.
- When a new Priority 1 channel is assigned, the radio automatically cancels the old Priority 1 channel assignment (radio service software programmable).
- When a new Priority 2 channel is assigned, the radio automatically cancels the old Priority 2 channel assignment (radio service software programmable).

## Selecting Squelch Operation

Tone Private Line® (PL), Digital Private Line™ (DPL), network ID, and carrier squelch operations are all available in the same radio on a per channel basis.

**Note:** Network ID is only available on ASTRO digital channels programmed by your system administrator or radio technician.

When in carrier squelch operation, all traffic on the channel is heard. When in PL, DPL or network ID operation, your radio responds to only those messages intended for you. PL, DPL, network ID and carrier squelch can be programmed by your system administrator or radio technician.

When the radio is operating in carrier squelch, the display shows the  status indicator.

## Smart PTT

Smart PTT is a feature used in conventional radio systems to keep radio users from talking over other radio conversations. Smart PTT is programmed by your system administrator or radio technician.

When Smart PTT is enabled in your radio, you are unable to transmit on an active channel. If you try to transmit (press the **PTT button**) on an active Smart PTT channel, you hear an alert tone, and the transmission is inhibited. The LED blinks red to indicate that the channel is busy.

Three radio-wide variations of Smart PTT are available:

<b><i>Transmit Inhibit on Busy Channel with Carrier</i></b>	With this feature enabled, you are prevented from transmitting if any activity is detected on the channel.
<b><i>Transmit Inhibit on Busy Channel with Wrong Squelch Code</i></b>	With this feature enabled, you are prevented from transmitting on an active channel with a squelch code or (if secure-equipped) encryption key other than your own. If the PL code is the same as yours, the transmission is allowed.
<b><i>Quick-Key Override</i></b>	This feature can work in conjunction with either of the two above variations. With this feature enabled, you are able to override the transmit-inhibit state by quick-keying the radio; in other words, two <b>PTT button</b> presses within the time programmed through radio service software (RSS) for <b>Smart PTT Quick-Key Timer</b> (default value is 1/2 second).

## Notes

# Special Radio Features

---

## Dynamic Regrouping

The dynamic regrouping feature allows the dispatcher to temporarily reassign selected radios to a single special channel so that they can communicate with each other. This feature, enabled in each radio by your system manager or service technician, is typically used during special operations. You will not notice whether your radio has this feature enabled until a dynamic regrouping command is sent by the dispatcher.

**Note:** If you select the dynamic-regrouping zone/channel using softkeys or other radio controls without being dynamically regrouped, you hear an short, low-pitched invalid tone.

When your radio has been dynamically regrouped, you hear a gurgle tone (unless you are already on the dynamic-regrouping zone/channel), and your radio automatically switches to the dynamic-regrouping channel. The display shows the name assigned to the dynamic-regrouping channel.

**Note:** When you use a radio-control knob or switch to select the zone or channel, you are not be able to scan or initiate a private conversation call until you select the dynamic regrouping position. You also hear a gurgle tone each time you press the **PTT button**. This is a reminder to you that you are transmitting on the dynamic-regrouping channel, not the zone or channel indicated by the position of the radio control.

However, in some cases the radio is programmed as a select-enabled radio: see page 63 for details.

- 1 Press the **PTT button** to talk and release it to listen.

- 2 For radios using only softkeys for zone and channel selection — When the dynamic regrouping is cancelled by the dispatcher, the radio automatically returns to the original softkey zone and channel before the radio was dynamically regrouped.

**OR**

For Radios Using Knobs or Switches for Zone and/or Channel Selection — Your radio automatically returns to the present knob/switch zone and/or channel position and the original softkey zone or channel selection when the dynamic regrouping is cancelled by the dispatcher.

## Reprogram Request

This feature allows you to notify the dispatcher that you want a new dynamic-regrouping assignment.

- 1 Press  until the display shows the **RPGM** softkey.

**OR**

Press the preprogrammed **Reprogram Request button** (see page 4); this takes you to the result of the action described in step 2.

- 2 Press  directly below **RPGM**.

The display shows **REPRGRM ROST**, indicating that the reprogram request has been sent to the dispatcher.

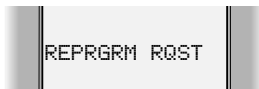

If you hear five beeps, the reprogram request was acknowledged by the dispatcher. Your radio returns to the home display.

**Note:** If the dispatcher fails to acknowledge the reprogram request within six seconds, you hear a low-pitched alert tone and the display shows **NO ACKNOWLDG**. Try again or press  to return to the home display.

- 3 Press the **PTT button** to resend the reprogram request again, or press  to hang up and return to the home display.

## Select Enable/Disable

The dispatcher may classify regrouped radios into either of the following two categories:

- Select-enabled radios are free to make channel changes to any available channel, including the dynamic-regrouping channel.
- Select-disabled radios cannot change channels since the dispatcher has specifically chosen to force the radio to remain on the dynamic-regrouping channel.

**Note:** You cannot use the scan and private conversation call features when your radio is select disabled.

## PTT-ID Receive

The PTT-ID receive feature allows you to see the Unit ID number of the radio you are currently receiving transmissions from. This ID can be a maximum of eight characters and can be viewed by both the receiving radio and the dispatcher. On trunking radios, press ◀ or ▶ to replace the displayed ID with the softkey menu selections; press  to return to the ID display.

## PTT-ID Transmit

The PTT-ID transmit feature is a per-channel feature in which your radio's ID number is automatically sent every time the **PTT button** is pressed. For analog voice transmissions, depending upon how your radio was programmed, your radio's ID can be transmitted at the beginning of a transmission, at the end of a transmission, or at the beginning and ending of a transmission. For digital voice transmissions, your radio's ID is sent continuously during the voice message.



If your radio has MDC-1200™ signalling and the ID is sent before the voice transmission, you hear a continuous low-pitched tone until the ID transmission is completed; this helps you avoid talking while the ID code is being transmitted.

To view your radio's ID number:

- 1 Press  until the display shows the **CALL** or **PAGE** softkey.

**OR**

Press the preprogrammed **Call button** or **Page button** (see page 4). This takes you to the result of the action described in step 2.

- 2 Press  directly below **CALL** or **PAGE**.
- 3 Press .

The display shows your radio's ID.

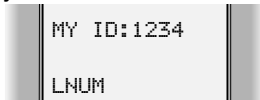

## Secure Operation

If your radio is programmed with secure operation, you may transmit in either clear or secure mode. Transmitting in secure mode ensures that no users other than the intended recipient(s) are able to decode your encrypted message.

### Selecting Secure or Clear Transmissions

Use the **Secure/Clear switch** (see page 4) to select secure or clear operation of the radio before initiating a transmission using the **PTT button**. This selection cannot be made when a transmission is in progress.

If a channel is programmed for secure-only operation, and the **Secure/Clear switch** is in the clear (E) position, when the **PTT button** is pressed, the display shows **SECR TX ONLY**, you hear a continuous, low-pitched invalid-mode tone, and the radio does not transmit until the **Secure/Clear switch** is set to the secure (ⓧ) position.

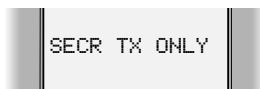



**OR**

If a channel is programmed for clear-only operation, and the **Secure/Clear switch** is in the secure (Ⓢ) position, when the **PTT button** is pressed, the display shows CLR TX ONLY, you hear an invalid-mode tone, and the radio does not transmit until the **Secure/Clear switch** is set to the clear (○) position

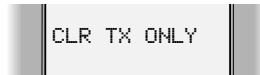

## Managing Encryption

Your radio may be programmed for either single key or multikey encryption. If your radio is programmed for single key encryption, your radio has a single encryption key and supports one encryption algorithm. The multikey feature allows your radio to be equipped with as many as 16 different encryption keys and supports up to two different encryption algorithms simultaneously (for example, DVP-XL™ and DES-XL; or DVP™ and DVI-XL™ or DES-OFB).

### KEY Loading

To load encryption keys into the radio:

- 1 Set up the radio and equipment as specified in the key-variable loader (KVL) manual.
- 2 When the KVL is attached to your radio, the display shows KEYLOADING, and all other radio functions are locked out.
- 3 Press the KVL's **PTT button** to load the encryption keys into your radio. When the key has been loaded successfully, single-key radios sound a short tone and multi-key radios sound an alternate tone.

### Key Erasure (KEY Zeroization) - Method 1 (Multikey Only)

- 1 Press ⏪ or ⏩ until the display shows the ERAS softkey.
- 2 Press ⏏ directly below ERAS.

The display shows the last user-selected and stored encryption key and the available softkey selections.

**Note:** The scan, telephone call or Private Conversation call feature cannot be selected while your radio is select disabled.

- 3 To erase all the encryption keys in the radio, press  directly below the ALL softkey.

The display shows ERS ALL KEYS and YES and NO for erase confirmation.



**OR**

To exit this menu and return to the home display, press  directly below the ABRT softkey.

**OR**

To select the displayed encryption key to be erased, press  directly below the SNGL softkey.

The display shows ERS SNGL KEYS and YES and NO for erase confirmation.

Press  or  to scroll through the encryption keys or use the alphanumeric keypad to enter the encryption key's placement in the list. The display shows the new selection on the upper line.

- 4 To exit the menu, press , the **PTT button** the ABRT softkey, or turn the **16-Position Select knob**.

### **KEY Erasure (All KEYS Erased) - Method 2**

- 1 Turn the radio on.
- 2 Press the **Top Side button** and **Emergency button** simultaneously.

**Note:** DO NOT press the **Emergency button** before pressing the **Top Side button** unless you are in an emergency situation. This sends an emergency alarm.



- 3 When all the encryption keys are erased, the display shows ERASED.

## MultiKEY

The multikey feature must be configured based on whether or not your radio is used for conventional applications or both conventional and trunked applications as described below:

<b>Multikey</b>	The encryption keys can be tied (strapped), on a one-per-channel basis by your system administrator or radio technician. In addition, you can have operator-selectable keys, operator-selectable indices, and operator-selectable key erasure. If talkgroups are enabled in conventional, then the encryption keys are strapped to the talkgroups.
<b>Trunked Multikey</b>	If you use your radio for both conventional and trunked applications, you have to strap your encryption keys for trunking on a per talkgroup or announcement-group basis. In addition, you may strap a different key to other features for example, dynamic regrouping, failsoft, emergency talkgroup, or emergency-announcement group.



### KEY Selection

- 1 Press  until the display shows the KEY softkey.
- 2 Press  directly below KEY.

The display shows the last user-selected and stored encryption key and the available softkey selections.

```

HW KEY 1
  PSET
SEL      ABRT
  
```

- 3 Press  or  to scroll through the encryption keys.

**OR**

Enter the number of the desired index.

**Note:** If an erased key is selected, the display alternately shows ERASED KEY and the key name.

- 4 To select the preset or default encryption key, press  directly below the PSET or PRESET softkey.

**OR**

To save the newly-selected key and return to the home display, press  directly below the SEL softkey.

- 5 Press , the **PTT button**, the **ABRT** softkey-related button, or turn the **16-Position Select knob** to exit this menu. If the selected key is erased, the display shows **KEY FAIL** and you hear a group of medium-pitched key fail tones.

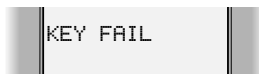

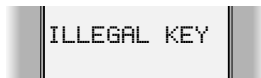

If the selected key is not allowed, the display shows **ILLEGAL KEY** and you hear a short, low-pitched illegal key tone.



**Index Selection**

The select-an-index feature allows you to select one or more groups of several encryption keys from among the available keys stored in the radio. For example, you may have a group of three keys structured to one index, and another group of three different keys structured to another index; by changing indices, you automatically switch from one set of keys to the other. Every channel to which one of the original keys was tied to now has the equivalent new key instead. Indexing allows the key-management controller to remotely change the keys within the index that is not currently being used without disrupting the operation of the radio.

- 1 Press  until the display shows **INDX**.
- 2 Press  directly below **INDX**.

The display shows the last user-selected and stored index and the available index softkey selections.

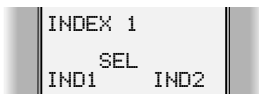

- 3 Press  directly below the desired index.

**OR**

Enter the number of the desired index.

- 4 To save the newly selected index, press  below **SEL**. The radio exits index selection and returns to the home display.

**Note:** Press  or the **PTT button** or turn the **16-Position Select knob** to exit this menu without modifying existing settings.

## Selectable Power Level

This feature allows you to select the power level at which your radio transmits messages.

**Note:** When the radio is powered on, it defaults to the programmed setting.

- 1 Press  until the display shows **PWR**.

**OR**

Press the preprogrammed **TX Power-Level Switch** (see page 4). This takes you directly to the result of the action specified in step 2.

- 2 Press  directly below **PWR**.

The display shows the current power-level state.

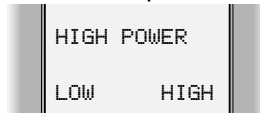

- 3 For shorter transmitting distance, press  directly below **LOW**. This conserves battery life.

**OR**

For longer transmitting distance, press  directly below **HIGH**. This transmission mode utilizes more battery power.

The new transmit power level is saved and your radio returns to the home display.

**Note:** Press  or the **PTT button** to exit this menu without modifying existing settings.

## Trunking System Controls

### Busy Override

When a talkgroup call is placed in a SmartZone™ system and the system is not able to obtain voice channels at all necessary sites, you hear a group of low-pitched busy tones. If preprogrammed, you may override the busy status by performing the following steps:

- 1 Press the **PTT button**; you hear a busy tone.
- 2 Release the **PTT button**.
- 3 Press and hold the **PTT button** a second time. The busy tone is heard again. After a few seconds, you hear a preprogrammed busy-override chirp and the radio sends in a busy-override request.

The talkgroup call is placed at all sites that have voice channel resources available. Other sites are added to the call as channels become available.

**Note:** Not all members of the talkgroup are able to hear a call when a busy override is requested.

### Dispatcher Interrupt

The dispatcher-interrupt feature allows the dispatcher to interrupt your radio and places you in a Private Conversation call with the dispatcher.

- 1 When your radio receives a dispatcher-interrupt call, you hear a repeating sequence of four, short, medium-pitched tones until you answer the call. The display shows `DISP INTRUPT` on the first line and `PLEASE WAIT` on the second line. The green LED flashes indicating that a call is being received.

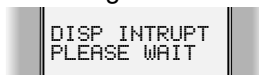

```
DISP INTRUPT
PLEASE WAIT
```

- When the second line displays the ID of the dispatcher who has initiated the dispatcher-interrupt, press the **PTT button** to talk and release it to listen.

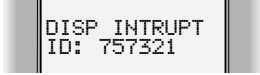

DISP INTRUPT  
ID: 757321

- When you are finished with your conversation, hang up by pressing . The radio returns to the home display.

## Failsoft

If a trunking system experiences a complete failure, the radio reverts to Failsoft operation and automatically switches to its Failsoft channel. During Failsoft, the trunking repeaters transmit a medium-pitched tone every 10 seconds. When the trunking system returns to normal operation, your radio automatically exits the Failsoft operation and returns to trunked operation.



FAILSOFT

## Out-of-Range

If you go out of range of the system and can no longer lock onto a control channel, the display alternately shows **OUT OF RANGE** and the currently selected zone/channel combination, and/or you hear a low-pitched tone. Your radio remains in this out-of-range condition until it (1) locks onto a control channel, (2) locks onto a failsoft channel, or (3) the radio is turned off.



OUT OF RANGE

## Site Lock

This feature allows your radio to lock onto a specific site and not roam among wide-area talkgroup sites. This is particularly useful when operating at the fringe of a system's coverage.

- 1 Press  until the display shows **SITE**.

**OR**

Press the preprogrammed **Site Lock/Unlock button** (see page 4).

- If the preprogrammed **Site Lock/Unlock button** is a side button, the site-lock state changes, and the new state is displayed momentarily.
- If the preprogrammed **Site Lock/Unlock button** is the top button. This takes you directly to the result of the action specified in step 2.

- 2 Press  directly below **SITE**.

The display shows the current lock state.

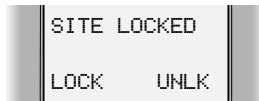

- 3 Press  directly below the desired condition (**LOCK** or **UNLK**). The new site-lock state is saved, and your radio returns to the home display.

## Site Trunking

If the zone dispatcher loses communication with any site, that site reverts to what is known as site trunking. Your radio alternately displays **SITE TRUNKNG** and the currently selected zone/channel combination. You are only able to communicate with other radios within your trunking site.

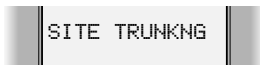

## Site View and Change

### *Viewing the Current Site*

- 1 Momentarily press the preprogrammed **Site Search button** (see page 4).



The display shows the number of the current site, or if the radio is scanning for a new site, the display shows `SCANNING SITE` until it locks onto a new site and then shows the number of the new site.

### ***Changing the Current Site***

- 1 Press and hold down the preprogrammed **Site Search button** (see page 4) to manually force the change to a new site.

You hear a tone, and the display shows `SCANNING SITE` while the radio scans for a new site. Then, the radio automatically returns to the home display.

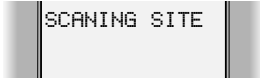

`SCANNING SITE`

## Notes

# Additional Information

---

## Troubleshooting

If you suspect a radio problem, check the following items before requesting service:

### 1 Radio Checks

- Be sure the radio is turned on and the **16-Position Select knob** is in the proper position.
- Replace or recharge the battery. The first time a new battery is used, it should charge a minimum of 16 hours.
- The antenna must be attached properly with its base flush against the top of the radio.
- Check that any accessories in use are properly connected.
- Test the radio from several different locations (especially if the problem occurs when the radio is used inside a building).
- Check the transmitter by transmitting to an alternate portable radio.

### 2 Operating Instructions

Review your operating instructions and ensure that you are using the radio properly.

- ### 3
- If, after following steps 1 and 2, your radio still has a problem, contact your system manager or review your service agreement and call your Motorola service representative as applicable.

If you do not have a service agreement on your radio, contact your nearest authorized Motorola service shop for guidance toward a prompt and expedient evaluation and/or repair.

## Radio Care

### Handling

- Do not pound, drop, or throw the radio unnecessarily. Never carry the radio by the antenna.
- Avoid subjecting the radio to an excess of liquids. Do not submerge the radio unless it is a ruggedized, XTS 3000 R model.
- Avoid subjecting the radio to corrosives, solvents or spirits.
- Do not disassemble the radio.
- Keep the accessory-connector cover in place until you are ready to use the connector. Replace the cover immediately once the accessory has been disconnected.

### Cleaning

To clean the external surfaces of your radio:

- 1 Combine one teaspoon of mild dishwashing detergent to one gallon of water (0.5% solution).
- 2 Apply the solution sparingly with a stiff, non-metallic, short-bristled brush, making sure excess detergent does not get entrapped near the connectors, controls or crevices. Dry the radio thoroughly with a soft, lint-free cloth.
- 3 Clean battery contacts with a lint-free cloth to remove dirt or grease.



Caution

**Do not use solvents to clean your radio. Spirits may permanently damage the radio housing.**

**Do not submerge the radio in the detergent solution.**

## **Service**

Proper repair and maintenance procedures assures efficient operation and long life for this product. A Motorola maintenance agreement provides expert service to keep this and all other communication equipment in perfect operating condition. A nationwide service organization is provided by Motorola to support maintenance services. Through its maintenance and installation program, Motorola makes available the finest service to those desiring reliable, continuous communications on a contract basis. For a contract service agreement, please contact your nearest Motorola service or sales representative, or an authorized Motorola dealer.

Express Service Plus (ESP) is an optional extended service coverage plan, which provides for the repair of this product for an additional period of either one or two years beyond the normal expiration date of the standard warranty. For more information about ESP, contact the Motorola Radio Support Center at 8000 West Sunrise Boulevard, Ft. Lauderdale, FL 33322.

## **Battery**

### **Battery Charge Status**

Your radio can indicate your battery's charge status through an LED and/or alert tones.

Refer to "Low-Battery Indication" on page 35.

### **Battery Recycling and Disposal**

Rechargeable batteries may be recycled. However, recycling facilities may not be available in all areas. Under various U.S. state laws and the laws of several other countries, batteries must be recycled and cannot be disposed of in landfills or incinerators. Contact your local waste management agency for specific requirements and information in your area.

## Additional Information

---

Motorola fully endorses and encourages the recycling of batteries. In the U.S. and Canada, Motorola participates in the nationwide Rechargeable Battery Recycling Corporation (RBRC) program for battery collection and recycling. Many retailers and dealers participate in this program.

For the location of the drop-off facility closest to you, access RBRC's Internet web site at [www.rbrc.com](http://www.rbrc.com) or call 1-800-8-BATTERY. This Internet site and telephone number also provide other useful information concerning recycling options for consumers, businesses, and governmental agencies.

# Index

---

## A

alert tones .....	7
antenna .....	15
attach .....	15
radio operating frequencies .....	12
remove .....	15

## B

backlight .....	5
battery .....	10, 11, 77
attach .....	11
battery life .....	10
charge status .....	77
charging .....	11
low-battery indicator .....	35
recycling and disposal .....	77
remove .....	12
belt clip .....	16
attach .....	16
remove .....	16
busy override .....	70

## C

calls	
individual .....	45
answering .....	50
calling a number from a list .....	49
calling last number dialed/ID	
number .....	48
selecting .....	46
using .....	47
talkgroup .....	43
selection .....	45
Channel Selector Lock .....	36
channel selector lock .....	36
common radio features .....	37

## D

data calls .....	38
sending .....	38
dispatcher interrupt .....	70

## E

emergency	
send an emergency alarm .....	39
emergency channel selector lock .....	43
emergency state .....	39
entering .....	40
exiting .....	42
keep-alive .....	42

## G

general radio operation .....	21
-------------------------------	----

## K

keypad lock .....	35
keypad tones	
muting .....	33

## L

LED indicators .....	5, 6
lists .....	26
selecting from .....	29
viewing a list .....	27

## N

notations used in this manual .....	1
-------------------------------------	---

## O

out-of-range .....	71
--------------------	----

## P

PL defeat .....	51
power level	
selectable .....	69
programmable controls .....	4
PTT-ID	
receive .....	63
transmit .....	63

## R

radio	
-------	--

## Index

---

- care .....76
  - things to avoid .....76
- cleaning .....76
- general features .....30
  - time-out timer .....34
- handling .....76
- on and off .....21
- service .....77
- turn off .....21
- turn on .....21
- receive / transmit
  - use preprogrammed monitor
    - button .....25
  - use preprogrammed volume set
    - button .....25
  - without using volume set and monitor buttons .....25
- receive/transmit .....24
- repeater access .....51
- repeater/direct .....52
  - selecting .....52
- S**
  - scan .....53
    - deleting nuisance channels .....55
    - dynamic priority change .....55
    - turning on/off .....54
    - viewing list .....56
  - secure operation .....64
    - selecting .....64
  - secure operations
    - encryption .....65
      - index selection .....68
      - key selection .....67
      - multikey .....67
  - select
    - a channel .....23
    - a zone .....22
  - site lock .....71
  - Smart PTT .....58
  - special radio features .....61
    - dynamic regrouping .....61
    - enable/disable .....63
    - reprogram request .....62
  - squelch
    - conventional squelch operation 37
    - non-project 25 digital squelch options .....38
    - project 25 digital squelch options 37
  - standard accessories .....10
- T**
  - Troubleshooting .....75
  - trunking system controls .....70, 71
    - failsoft .....71
    - site trunking .....72
- U**
  - universal connector cover .....17
    - attach .....18
    - remove .....17
- X**
  - XTS 5000 model I radio .....3
    - physical features .....4
- Z**
  - zones and channels .....22







**MOTOROLA**

Motorola, Inc.  
8000 West Sunrise Boulevard  
Ft. Lauderdale, FL 33322

MOTOROLA, the Stylized M Logo, and ASTRO are registered  
in the U.S. Patent and Trademark Office. All other product or  
service names are the property of their respective owners.

© Motorola, Inc. 2004

All rights reserved. Printed in U.S.A.



**6881083C75-A**