

CradlePoint Vehicle Best Practices Installation Guide

Using CradlePoint Routers in 12V and 24V Vehicles

Revision 1.2

Overview

The automotive environment can be particularly harsh for electrical equipment such as routers and mobile devices. Power in automotive systems is not stable and is often subject to fluctuations and noise.

Vehicle electrical systems are typically 12V or 24V, but the actual voltage can vary widely depending on the condition of the batteries and whether the engine is off, cranking, or running. Just as important, many potentially damaging transient voltages exist on vehicle power wiring. These transients, sometimes called “spikes”, are caused by motors for electric windows, solenoids for door locks, alternators, relays, light switches, loose electrical connections, and corroded battery terminals. The inductance in the vehicle’s wiring harnesses may exacerbate these transients. Transients of hundreds of volts, both positive and negative, can be generated with the potential to cause damage to any electrical equipment.

Our COR family of products can operate safely on 9–18 volts DC. However, for reliable operation in a vehicle, COR requires additional filtering and conditioning in 12V vehicles and additional voltage regulation in 24V systems. Most other CradlePoint routers are specified to operate safely from 11.4 to 12.6 volts and require regulation and filtering for all vehicle installations.

For proper and safe installation, the router must be connected to a fused circuit in the vehicle.

This paper will provide background on the problems and solutions as well as guidance for the installation of CradlePoint devices. We’ll recommend some commercially available products to help minimize the effects of the harsh automotive power environment.

Basic System (no protection)

It is possible to quickly wire a basic 12 volt system such as the simple installation shown in this diagram where power is provided to the router by connecting the 12V input lead from the router to a connection in the vehicle fuse block and the ground wire to a connection in the vehicle fuse block and the ground wire to chassis ground. However, this method provides no protection against voltage variations or voltage transients. Erratic operation or even damage to your CradlePoint product is much more likely than if the methods shown in the following pages are used to condition the power provided to your CradlePoint product or other mobile device. CradlePoint warranties may be void for installations without proper power protection.

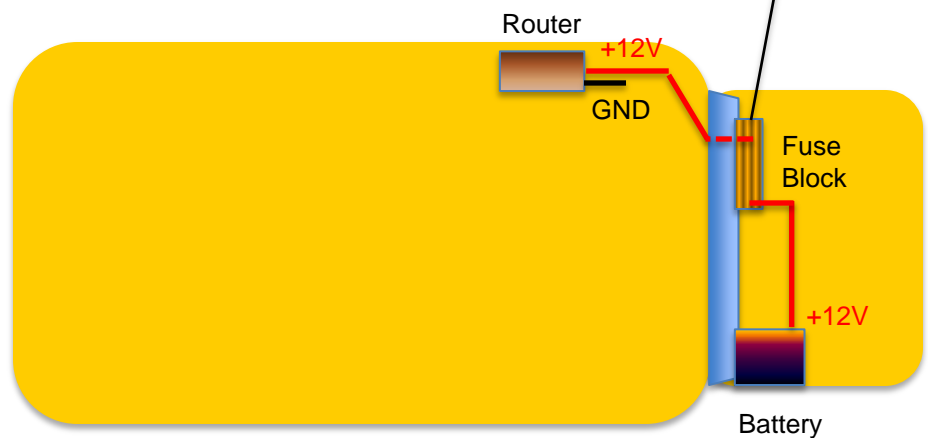
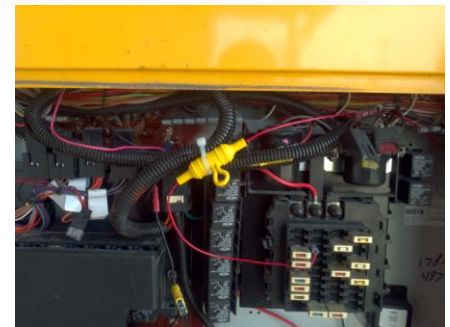

Power Management

These devices monitor the state of the battery and other lines such as the ignition switch to determine if power should be applied to the mobile device. Possible features provided by these may include the following:

- Provides power only when ignition switch is turned on.
- Monitors the battery voltage. If the battery voltage is too low or too high power to the mobile device is not allowed.
- Monitors whether the starter motor is engaged. Does not apply power to the mobile device while engaged.
- May allow the device to remain powered on for a specified time after the ignition is switched off to prevent battery drain. This time is typically user programmable.

Battery Voltage During Engine Start

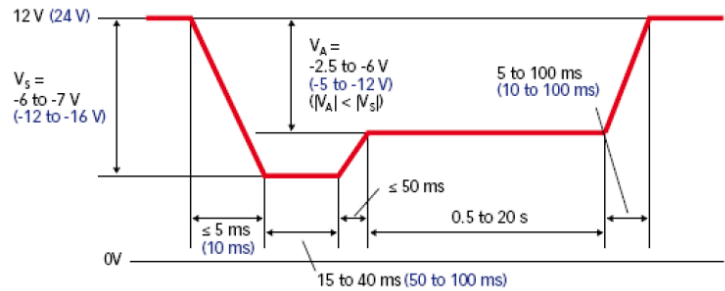

This graph shows how the voltage available from the battery is reduced significantly when the starter motor is engaged. The voltage may fall well below the recommended minimum voltage required by the router causing "brown out" conditions and possible malfunction.

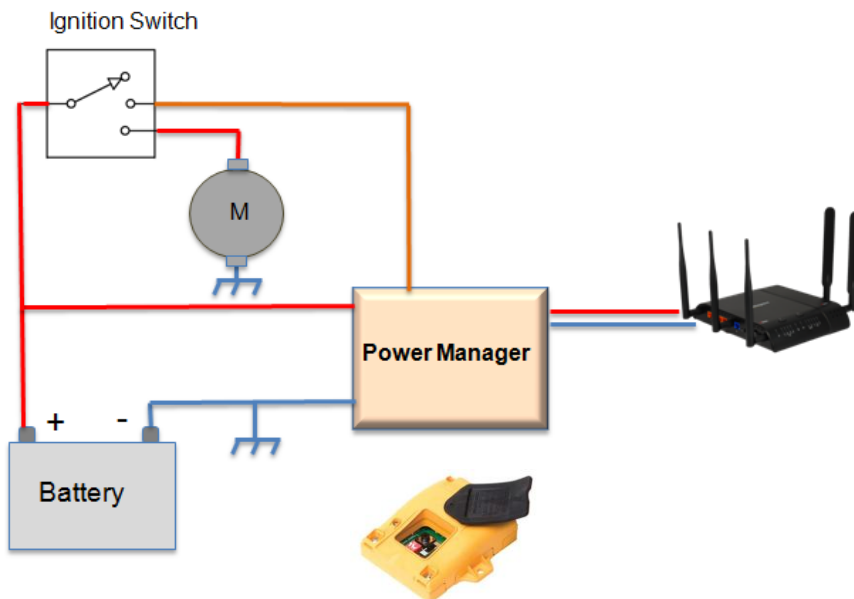

Voltage Regulation

Most vehicles are designated as either 12 or 24 volt systems, yet even though the battery is designated as 12 volts the actual voltage at its terminals during normal vehicle operation is typically about 13.6V. However, depending on its age, state of charge, and electrical load can typically range between 10 and 16 volts.

24 volt systems have similar characteristics and can range between 17 and 32 volts during normal operation.

Depending on model, CradlePoint routers can accept an input voltage of 9–18 volts which means some sort of voltage regulation and conditioning is generally required.

DC to DC Converters

Commercially available DC-DC converters take a wide voltage range from the battery and provide a regulated DC voltage output, typically about 13.6 volts. These converters should supply low ripple voltage, typically less than 250mV. Higher quality converters may also provide features such as reverse polarity protection, isolation, current limiting, short circuit protection, and overvoltage protection.

For a 24 volt system a standard regulator that simply lowers the voltage to 12–14 volts is acceptable. In a 12 volt system a regulator may need to either boost the voltage or reduce it. This dual mode regulator may be somewhat more expensive but will protect against “brown out” conditions caused by low input voltage.

It is important that the DC-DC converter can provide enough power for all devices with some extra safety margin (reserve power). Do not use an underpowered converter.

Vehicle Type	Input range to DC-DC Converter	Typical Output Voltage
12 Volt System	10–16 VDC	13.6 VDC
24 Volt System	20–50 VDC	13.6 VDC

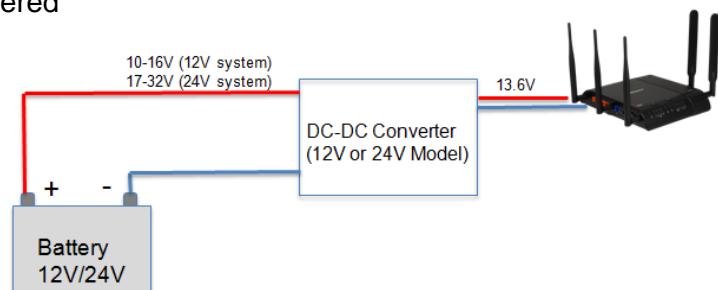

Filters

Voltage transients on the router's 12V input power lines may cause erratic behavior or damage. This "noise" can range in frequency from a single spike to a few kilohertz or hundreds of megahertz and is typically caused by electromechanical components in the vehicle, or even by additional electrical accessories installed in the vehicle.

Filters may help control these transients, however good installation techniques must be followed to ensure best router performance and protection.

➤ **Important** - Filters should be placed as close as practical to the router input power. Keep power lines to the device short. Failure to do so may reduce the effectiveness of the filter.

➤ Noise filters can be as simple as a capacitor (or two) placed across the 12V power line into the device. Adding an inductor and second capacitor to form a "pi" filter is more effective.

➤ Capacitors (caps) should be rated at least 150% of the expected voltage and a low ESR is preferred. A higher temperature rated cap will be less likely to fail over time.

➤ Caps have effective frequency ranges depending on the material used in their construction.

➤ Aluminum electrolytic, or "metal can", caps are used for lower frequency noise and voltage dips. **These caps have positive and negative terminals and must be connected correctly or damage will occur.** Capacitance values ranging from tens to hundreds of thousands of microfarads (uF) are available. For example a 5000 uF 35V 85°C aluminum capacitor would be a good starting value.

➤ Ceramic capacitors are used to control high frequency noise. It is critical to keep these as close a possible to the device input and keep lead lengths short. Typical values are 0.001–0.47uF, 50VDC.

➤ Inline inductors must be capable of handling the full load current of the device(s) attached to it.

➤ Pi filters are typically sold as "noise filters" by automotive audio stores. These must also be able to handle full load current.

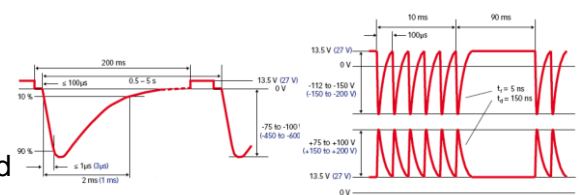
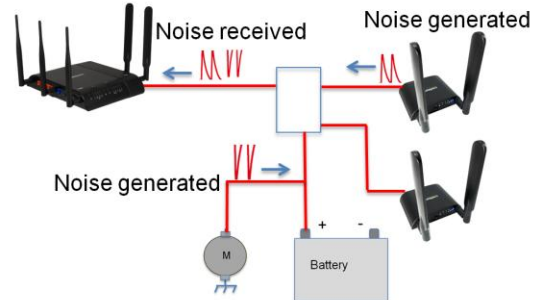

Standardized Examples of Automotive Transients (ISO-7637-2)

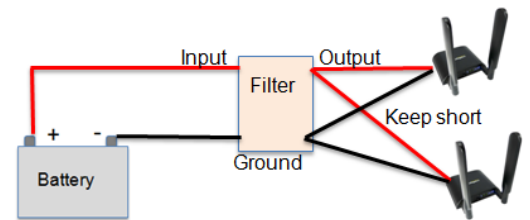

Location of the filter is important. Keep lines to mobile devices short

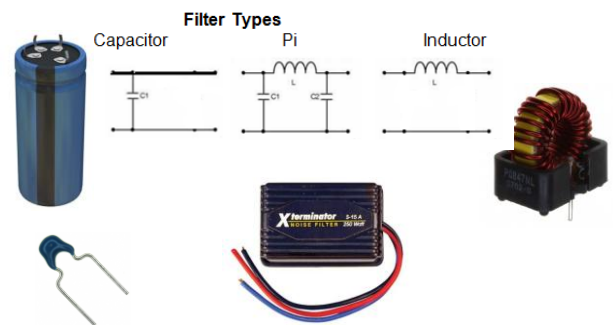

Filter component types. Pi is preferred.

Installation, Fusing and Wiring

Proper installation of the power conditioning devices in relation to the mobile device you are trying to protect is important.

- It is best to locate all conditioning devices such as DC-DC converters, power management devices, distribution blocks, and filters as close to the router equipment as possible. That being said, some are more critical than others.
- Filters and distribution blocks should be located as close to the mobile device(s) as possible. Long power leads from the filter to the mobile device can degrade or nullify filter performance.
- Use the proper wire size for the amount of current being drawn. Long cable lengths with undersized wire will result in voltage losses over the length of the cable and can possibly overheat (see table for recommended wire size).
- Use of a dedicated ground wire, rather than attaching to chassis ground, may be preferred. Chassis ground can be susceptible to corrosion effects and intermittent connections.

- Isolation between devices is recommended. Noise generated by one device can affect another. If multiple devices are connected at the same distribution point it may be necessary to filter each device separately.
- For proper and safe installation, the router must be connected to a fused circuit in the vehicle. For the COR family of products this fused circuit requires a 1.5A maximum time delay (slow blow) high interrupting rating fuse. If the supply connection is made directly to the battery, the fuse should be installed in the positive lead. For North America, a UL Listed fuse is to be used.

AMPS	Cable Length (AWG)	
	10'	20'
3–10	#14	#12
11–20	#14	#10
21–35	#8	#6

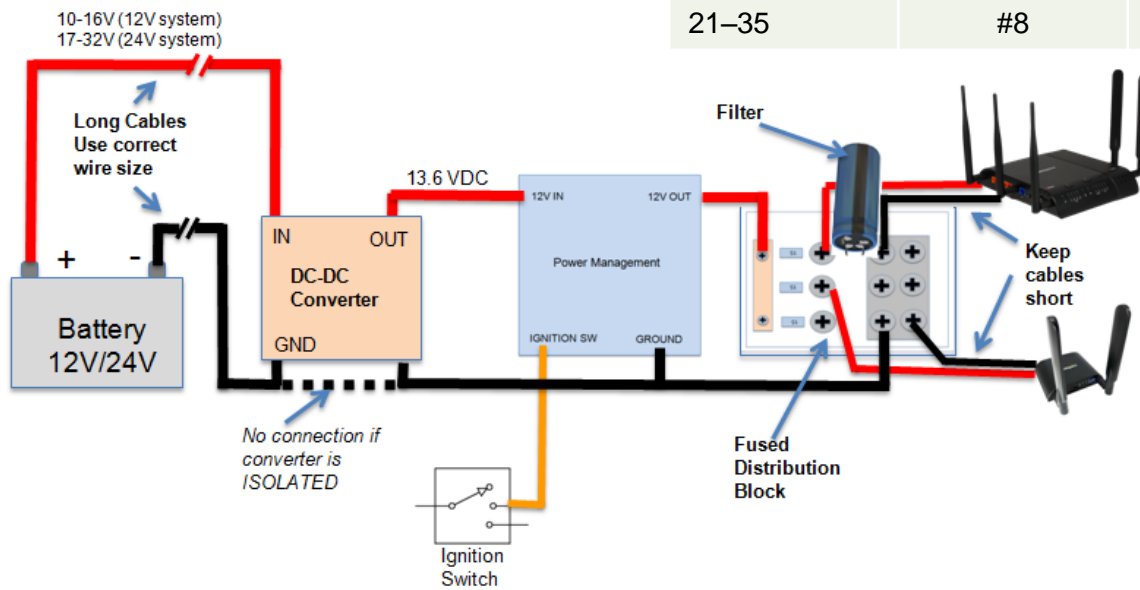

Possible Installation Configuration

Mechanical and Thermal

Electronics mounted in vehicles may subject to high levels of mechanical and thermal stress. It is important to understand that these parameters be addressed to ensure a reliable installation.

- Be sure the router is securely mounted within the vehicle. For example with the COR IBR600 family of routers includes a mounting bracket. This bracket can hold the router solidly in most installations. In high shock environments it may be advisable to add a supplemental cable tie to secure the router in the bracket.
- Vibration can cause early failure if not reduced to an acceptable level. Using the same COR IBR600 mounting bracket as an example, special anti-vibration rubber grommets such as the Keystone 773 (available from DigiKey) may be used. Insert the grommets and then tighten the screw to the point where the grommet just begins to compress to provide vibration isolation.
- Thermal ratings must be taken into consideration for reliable operation. All devices and components used in the installation are subject to the same thermal stresses. For example the COR IBR 600 is rated for ambient temperatures from -20°C to 60°C (-4°F to 122°F). Various power conditioners may have lower or higher ratings. Take care that your installation is within the thermal ratings of each device.
- The ambient thermal environment may be affected by many things. Lack of ventilation, being mounted in an auxiliary box, or being mounted where the sun heats it can all increase the relative ambient temperature. Care must be taken to understand these thermal aspects.

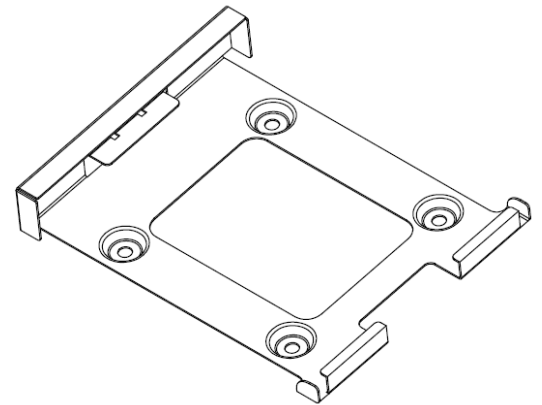

COR IBR600 Mounting Bracket

